

ESR10系列不同臂长机型运动范围参数 ESR10 series range of motion parameters for different arm lengths			
机型名称 The name of the model	ESR10-600Z20	ESR10-700Z20	ESR10-800Z20
a. 第1轴臂长+第2轴臂长 (mm) a. 1st axis arm length+2st axis arm length (mm)	600	700	800
b. 第1轴臂长 (mm) b. 1st axis arm length (mm)	225	325	425
c. 最大运动范围 (mm) c. Maximum range of motion (mm)	661.5	761.5	861.5
d. 第1关节运动范围 (°) d. Range of motion of the 1st joint (°)	132		
e. 第2关节运动范围 (°) e. Range of motion of the 2st joint (°)	150		
f. 运动范围 f. Range of motion	212.4	187.5	212.5
g. 后方运动范围 g. Rear range of motion	525.6	592.5	659.4
h. 第1关节机械停止位的角度 (°) h. The angle of the mechanical stop position of the 1st joint (°)	1		
i. 第2关节机械停止位的角度 (°) i. The angle of the mechanical stop position of the 2st joint (°)	1.5		
j. 机械停止位的范围 j. The range of mechanical stop bits	207.2	179	202.8
k. 后方机械停止位的范围 k. The range of the rear mechanical stop bits	528.5	596.7	664.9
m. 运动范围 m. Range of motion	420	330	320
n. 运动范围 n. Range of motion	300		

EFORT	
埃夫特智能装备股份有限公司 EFORT Intelligent Equipment Co., Ltd.	
比例 Scale	1:1 页码 Page
运动范围图 Robot workspace	
修订记录 revision record	ESR10-800Z20

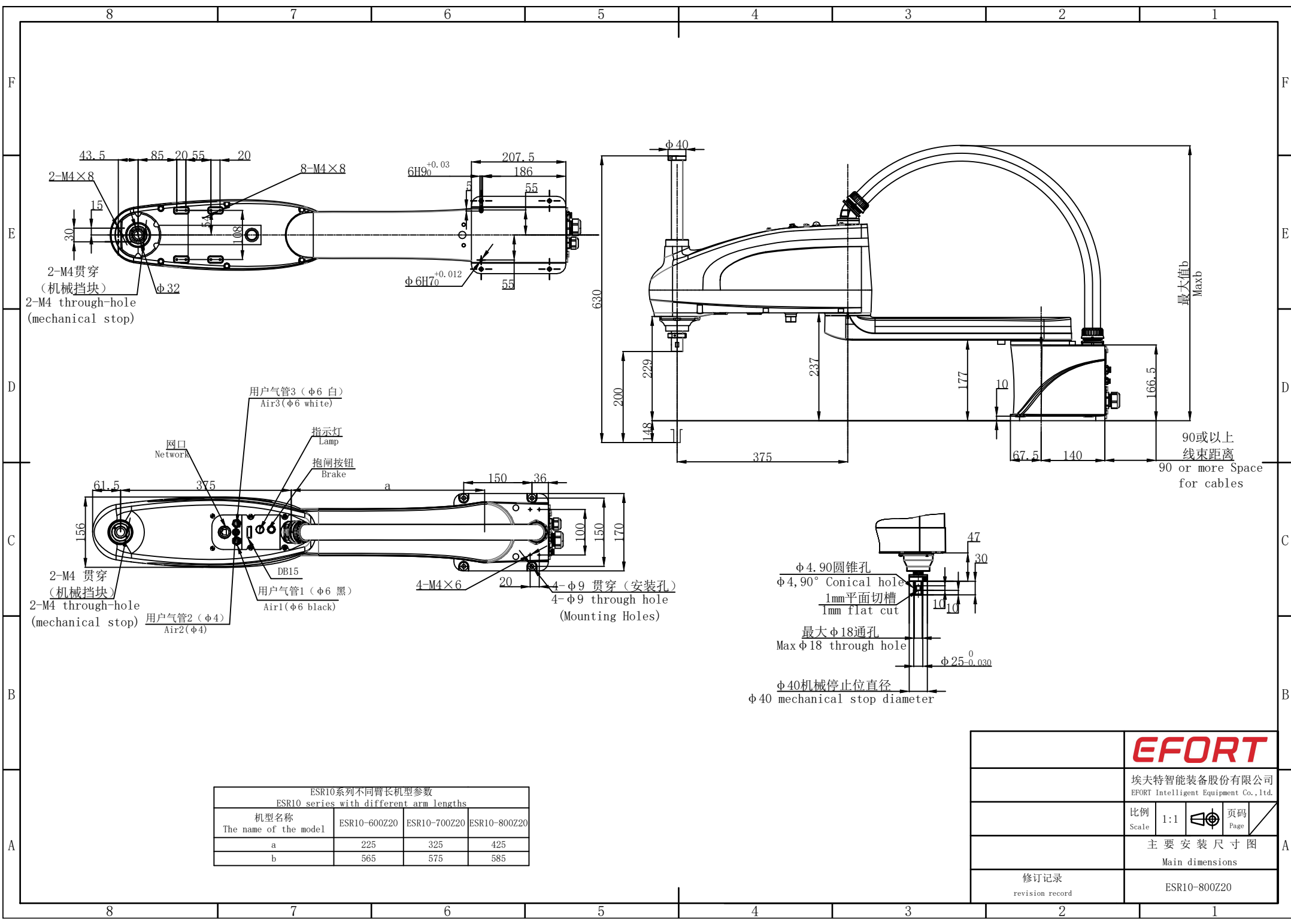

ESR10系列不同臂长机型参数
ESR10 series with different arm lengths

机型名称 The name of the model	ESR10-600Z20	ESR10-700Z20	ESR10-800Z20
a	225	325	425
b	565	575	585

EFORT	
埃夫特智能装备股份有限公司 EFORT Intelligent Equipment Co., Ltd.	
比例 Scale	1:1
页码 Page	
主要安装尺寸图 Main dimensions	
修订记录 revision record	
ESR10-800Z20	