

Base mounting size diagram  
底座安装尺寸图

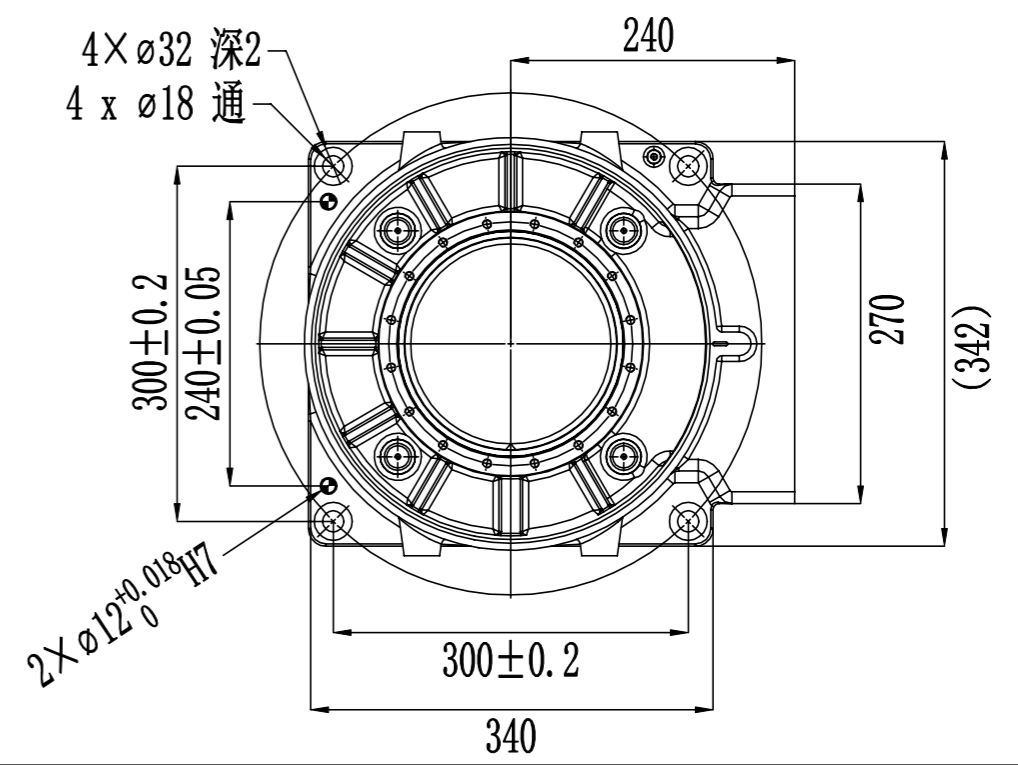

A

B

零件代号 part code
借(通)用件登记 registration for shared(interchangeable) parts
旧底图总号 unmodified serial number
底图总号 base map serial number
签字 signature
日期 date

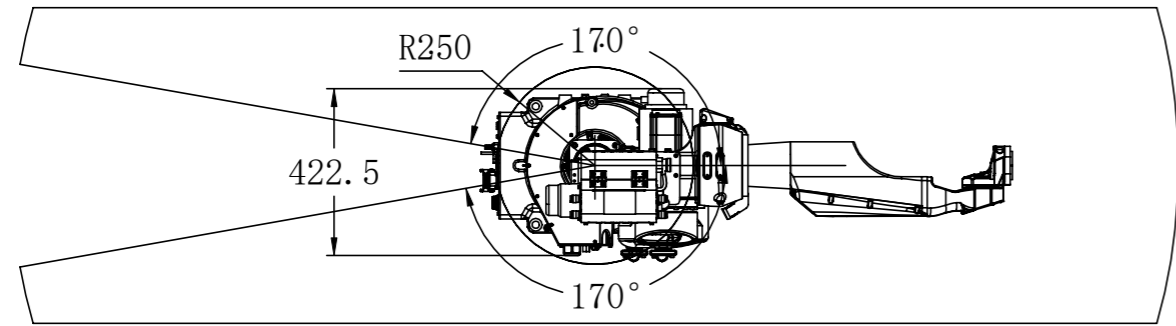

End flange mounting size diagram  
末端法兰安装尺寸图

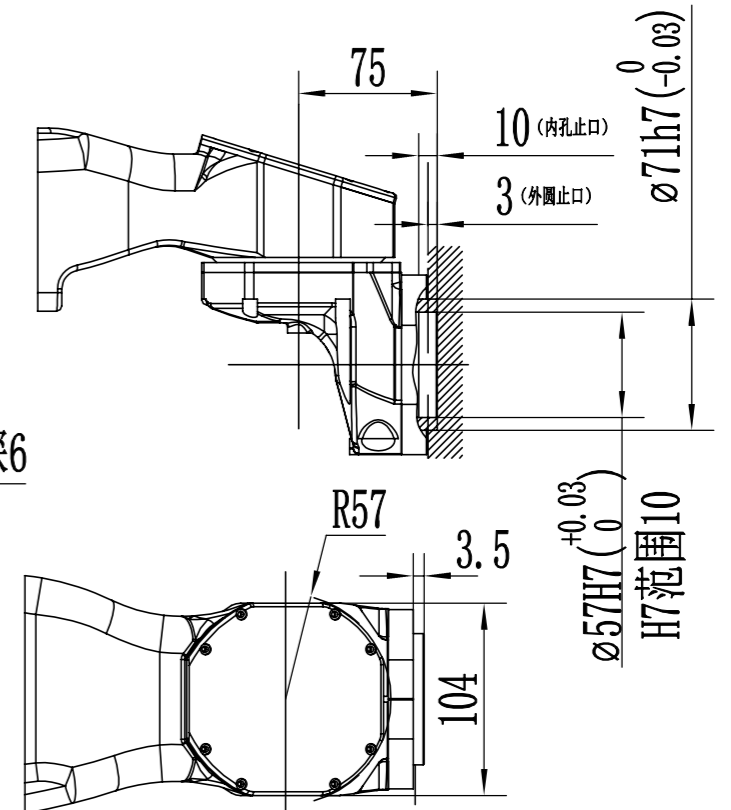
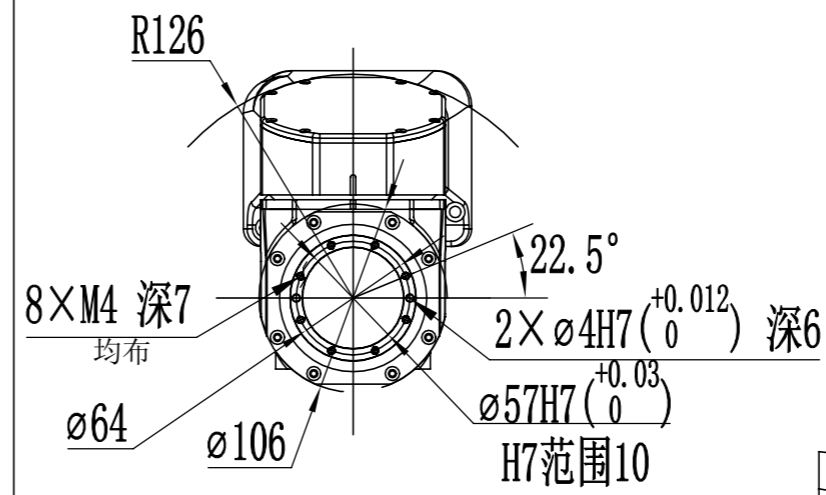

标记 Sign	处数 Number of places	分区 Partition	更改文件号 Change file number	签名 Autograph	年、月、日 Date
	签名 Autograph	年、月、日 Date		签名 Autograph	年、月、日 Date
设计 Design			标准化 Standardization		
审核 Review			校对 Proofread		
工艺 Technology			批准 Approval		

阶段标记 Stage marker	重量(Kg) Weight	比例 Scale
		1:15
图幅A3 投影法 Sheet Projection	页码 Page	1/1

埃夫特智能装备股份有限公司  
EPORT Intelligent Equipment Co., Ltd  
运动范围图  
Robot workspace  
ER12H-1600

1

2

3

4