



Electrical cabinet user Manual
电柜使用手册
(B&R Cabinet)

Rev. 1.0

第一版

CMA (WuHu) Robotics CO.,LTD
希美埃（芜湖）机器人技术有限公司

CONTENTS 目录

1	第一章 ELECTRICAL CONNECTION 电气连接.....	3
1.1.	INTRODUCTION 介绍	3
1.1.1	Description of the Electrical Cabinet 电柜说明	3
1.1.2	Technical specifications 技术规格	6
1.1.3	Symbols adopted 符号说明	6
1.2	GENERAL SAFETY STANDARDS 基本安全标准	7
1.3	CONNECTIONS 连接	9
1.3.1	Transport 运输	9
1.3.2	Installation 安装	10
1.3.3	Connecting earth cables 地线连接	11
1.3.4	Connecting to power supply 电源接线	12
1.3.5	Connecting the pendant (only PTP version)示教器的连接（PTP 版本）	13
1.3.6	Connecting the Robot 连接机器	14
1.3.7	Connecting safety devices 安全设备连接	19
1.3.8	Available input signals (X2)可用的输入信号（X 2）	29
1.3.9	Available output signals (X3)可用输出信号（X3）	31
1.3.10	Connecting the start limit switch and encoder (PTP/APS versions)连接起 动限位开关和编码器（PTP / APS 版本）	35
1.3.11	Connecting the encoder for plant managing (APS version)喷涂编 码器的连接（APS 版）	39
1.3.12	Connecting the Measure Barriers (APS version 连接测量光栅 (APS 版)	43
1.3.13	Connecting sensors for 3D option (option 3D)连接 3D 属 性的传感器（3D 选项）	45
1.3.14	Connecting the Start pedal for carousel loading (G models)连 接启动踏板至自带转盘型机器人（G 型）	46
1.3.15	Connecting Proportioning valves (CAPV accessory)连接比例 阀（CAPV 附件）	47
1.3.16	Ethernet connection (standard)以太网连接（标准）	50
1.3.17	Connecting the Profibus module (PROFI accessory)连接 Profi bus 总线模块（PROFI 附件）	51
1.4	AVAILABLE COMMUNICATION INTERFACES 可用的通信接口	53
1.4.1	Ethernet communication (standard)以太网通信（标准）	53
1.4.2	Communication Profibus (accessory PROFI) Profibus 总线 通讯（PROFI 配件）	57
1.5	AXIS ERROR MESSAGES 关节轴错误信息	60
2	第二章 MAINTENANCE AND ELECTRICAL REPAIRS 维修和电 器维修.....	67
2.1	SPECIFIC SAFETY RULES 具体的安全规则	67
2.2	MAKING THE SAFE 确保工业机器人安全	69
2.3	SCHEDULED MAINTENANCE 日常维护	70
2.4	SUMMARY OF WORK 工作摘要	71
2.5	DESCRIPTION OF ROUTINE MAINTENANCE WORK 日常维护工 作说明	72
2.5.1	Checking and replacing the dust filter (version with forced ventilation only)检查和更换滤尘器(强制通风版本)	72
2.5.2	Cleaning inside the cabinet (version with forced ventilation only) 清洁电柜内部（强制通风版本)	73
2.5.3	Checking operation of cabinet ventilation (version with forced ventilation only)检查操作柜通风（强制通风版本）	74

2.5.4	Checking operation of the drive and heat sink fans 检查驱动器和散热器风扇的运行	75
2.5.5	Checking indicators and alarm warning devices are in proper working order 检查指示灯和报警报警装置处于正常工作状态	76
2.5.6	Checking safety devices are in proper working order 检查安全装置是否处于正常工作状态	77
2.5.7	Checking the cabinet-robot connecting cable for damage 检查机器人电柜连接电缆是否损坏.....	78
2.6	OCCASIONAL WORK 临时性工作	79
2.7	NON-ROUTINE MAINTENANCE 非日常维护	79
2.7.1	List of spare parts for cabinet with wiring diagram 0330 电柜备件接线图 0330 清单	81
2.7.2	Replacing fuses 更换保险丝	82
2.7.3	Replacing a drive 更换驱动器	85
2.7.4	Replacing the heat sink cooling fans 更换散热器散热风扇.....	88
2.7.5	Replacing the drives' cooling fans 更换驱动器的散热风扇.....	88
2.7.6	Replacing the safety PLC 更换安全 PLC	89
2.7.7	Replacing the Display (only APS version) 更换显示器（只有 APS 版本）	91
2.7.8	Replacing the cooling fan (version with forced ventilation only) 更换冷却风扇（强制通风版本） .	92

1 第一章 ELECTRICAL CONNECTION 电气连接

1.1. Introduction 介绍

1.1.1 Description of the Electrical Cabinet 电柜说明

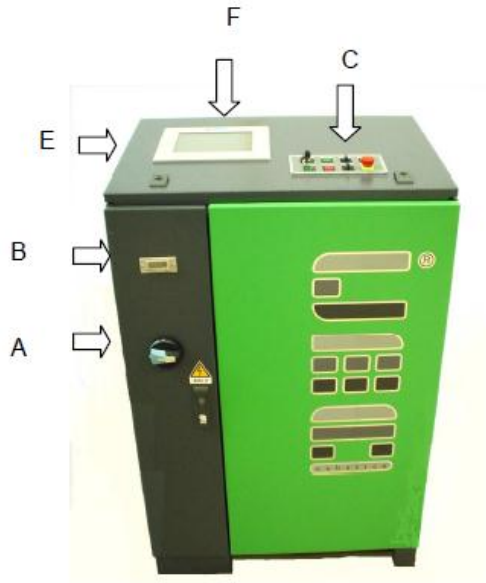

The devices that can be seen on the outside of the PATH version electrical cabinet are:

- A) ON/OFF switch 电柜开关
- B) Hour meter 生产时间计时器
- C) Main Control Panel 主控制面板
- D) Not used 未使用
- E) USB port, Ethernet port USB 接口, 以太网接口
- F) Display 8,4" 8.4 寸显示器

PATH = Self learning programming
PATH=自主学习编程

Figure1:Electrical Cabinet exterior PATH
PATH 版本电柜外观

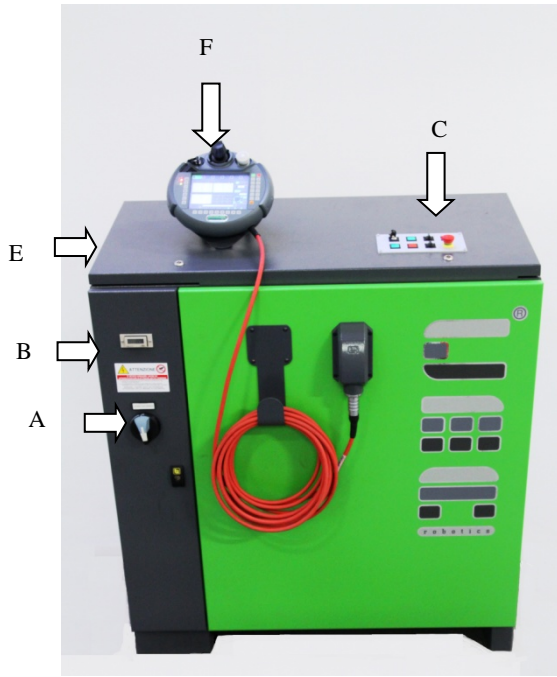

The devices that can be seen on the outside of the PATH/PTP version electrical cabinet are:

PATH / PTP 版本电柜外部设备:

- A) ON/OFF switch 电柜开关
- B) Hour meter 生产时间计时器
- C) Main Control Panel 主控制面板
- D) Not used 未使用
- E) USB port, Ethernet port USB 接口, 以太网接口
- F) Pendant 示教盒

PTP = Point To Point programming

PTP=点到点编程

Figure 2:Electrical Cabinet exterior PATH/PTP
PATH/PTP 版本电柜外观

The devices that can be seen on the outside of the APS version electrical cabinet are:

APS 版本电柜的外部设备:

- A) ON/OFF switch 电柜开关
- B) Hour meter 计数器
- C) Main Control Panel 主控制面板
- D) Manual Control Panel 手动控制面板
- E) USB port, Ethernet port USB 接口, 以太网接口
- F) Display 17" 17 寸显示器

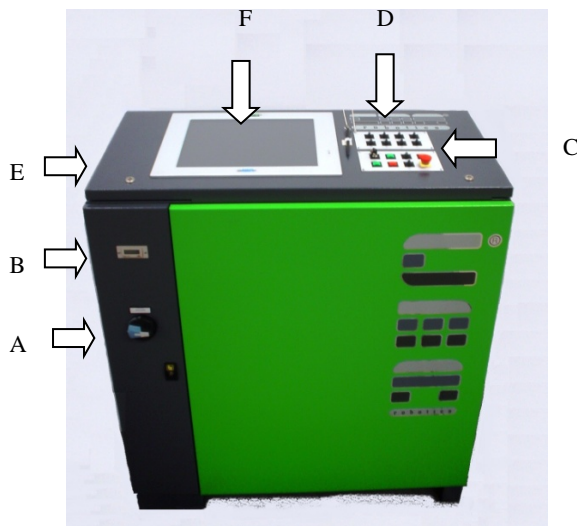

APS = Automatic Painting System

APS = 自动喷涂系统

Figure3:Electrical Cabinet exterior APS
APS 版本电柜外观

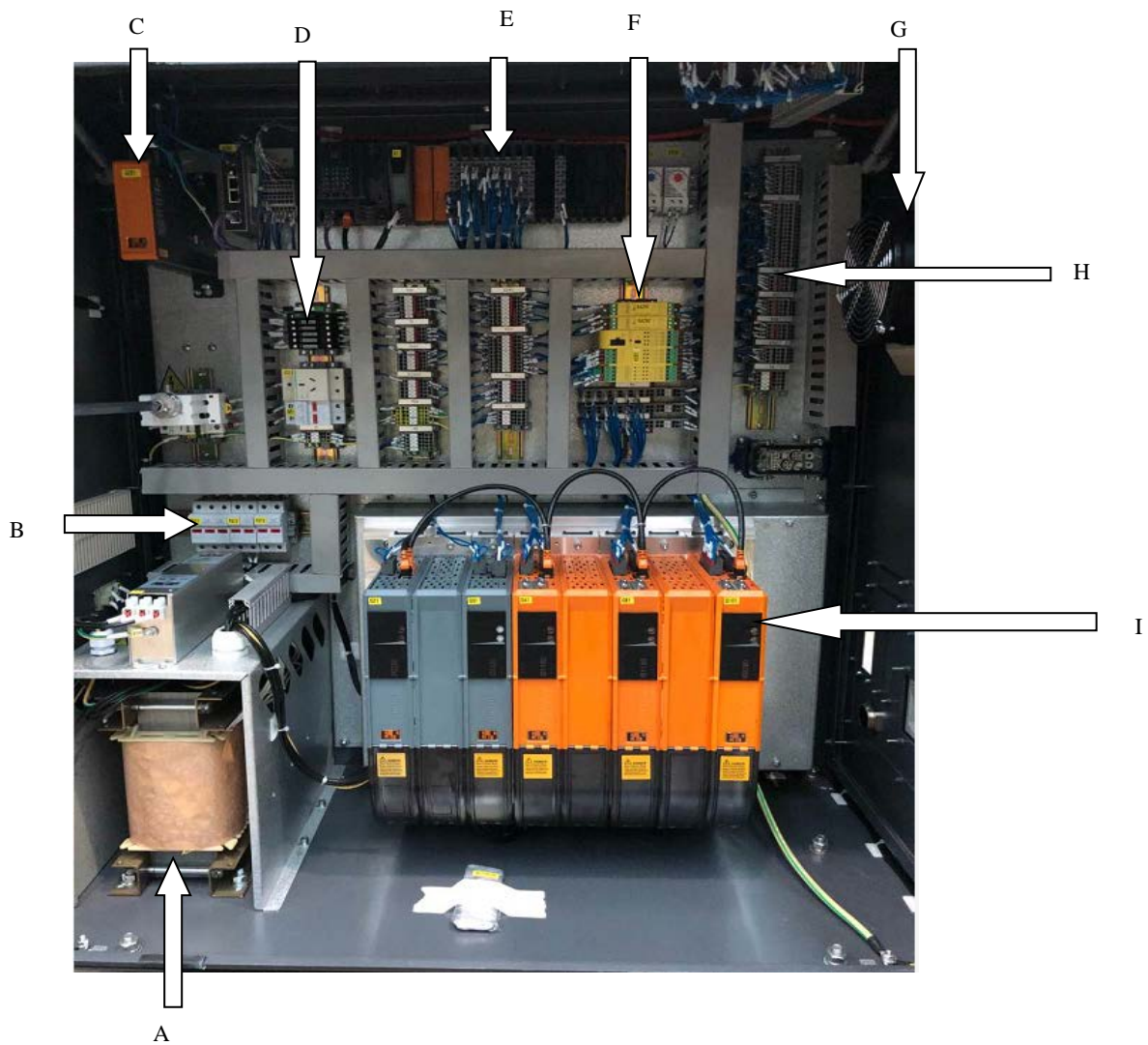

Figure 4 :Electrical Cabinet internal
电柜内部

The main parts inside the electrical cabinet are:

电柜内部的主要部件:

A) Isolation transformer (optional)

隔离型变压器（可选）

B) 10x38 380VAC fuse group

10x38 380VAC 熔断器

C) Industrial PC

工控机

D) 24VDC lamellar fuse group

24VDC 片状保险丝

E) I/O (Input Output) board assembly

IO（输入输出）

F) Safety PLC

安全 PLC

G) Forced ventilation

压力通风风扇

H) Interface terminal blocks

接口接线端子

I) Bank of Drives

驱动器背板



1.1.2 Technical specifications 技术规格

Dimensions 尺寸	1000mmx500mmx1200mm
Weight 重量	250kg
Power supply 供电	3x400V 50/60 Hz
Installed power 安装功率	5KVA
Starting current at 400V 400V 时的启动电流	10A
Workplace temperature range 工作场所的温度范围	0° 到 40° C
Storage temperature range 存储温度范围	-25° 到 55° C
6-axis GR series robots that can be used in conjunction 联合使用的 6 轴 GR 系 列机器人	B&R system ROBOT

1.1.3 Symbols adopted 符号说明

The following symbols are used here in:

采用符号如下所示:

Symbol 符号	Description 描述
	PROHIBITION 禁止 Sections marked with this symbol contain instructions on incorrect behaviour and misuse that can result in hazards and, consequently, are prohibited. 带有此标志的内容包含了不正确的操作行为和可能导致的危害的误用行为，因此是被禁止的。
	MANDATORY ACTION 强制性措施 Sections marked with this symbol contain instructions that you are required to follow. 带有此标志的内容包含您必须遵守的说明。
	WARNING 警告 Sections marked with this symbol describe operations that can lead to hazardous situations if not carried out correctly. 带有此标志的内容所描述的操作，如果不能正确地进行，可能导致危险情况发生。

And the following conventions are adopted
采用以下规定

AUTO – TEACH .



White writing on a black background refers to a control found on the Robot's control panel.
书写在黑色背板上白色字体表示的是在机器人控制面板上的控制模式。

Add .

LIST .

REC .



Writing on a grey, blue or red background refers to buttons to be pressed on the Robot pendant touch screen display.
灰色、蓝色或红色背景的标识是指机器人示教器上被按下的按钮。

Speed

Spraying distance



Writing in bold refers to labels found on the Robot pendant display.
用粗体书写的标签表示在机器人示教盒屏幕上。

Edit Out .



White writing on a blue background refers to dialog boxes that appear on the Robot pendant display.
在蓝色背景上的白色字体表示在示教盒屏幕上的对话框中。

- Press the **STOP** button to stop the machine immediately.
- 按下 **STOP** 键立刻将机器人停下。



One or more arrows indicate an action or a series of actions that the operator is required to perform in order to follow a procedure.
一个或多个箭头表示操作者需要按照该流程进行操作。

1.2 General safety standards 基本安全标准

MANDATORY ACTION

强制性措施

Work on the electrical system's equipment can only be carried out - in accordance with electro technical standards - by an electrician, or by a trained person under the supervision of an electrician.

按照电工技术标准，电气系统设备的运行只能由电工或电工监督下受过培训的人操作。

Only use tools that are suitable for the maintenance and repair work. When working on electrical parts, only use tools insulated against electricity.

只能使用合适的工具进行保养和维修工作。当对电气部件操作时，只能使用电绝缘工具。



Make sure the facility's earthing system is in proper working order.

确保设备的接地系统处于正常工作状态。

If the electrical control unit in which the 's electrical connections will be made does not have a residual current device already, install a thermomagnetic RCD set to 0.500 mA (I Δ n) featuring marking showing conformity to international standards.

如果机器人连接的电气控制单元没有漏电保护器，安装热磁漏电保护器设置为 0.500 mA(I Δ n)标志确保符合国际标准。

Check that the voltage and frequency of the main power line to which this to be connected matches the machine's ratings.

检查该主电源线，以使工业机器人是要连接的电压和频率与机器的额定值相匹配。

Cable raceways and the actual connecting cables must be made from flame-retardant insulating material and have at least an IP40 protection rating.

电缆电线管道和实际的连接电缆必须由阻燃绝缘材料制成，防护等级至少为 IP40。

If the robot is too far from the main electrical cabinet, it is advisable to install a stop device near the actual machine, which can also be used for emergency stops.

如果工业机器人离主电柜太远，建议在实际设备附近安装一个停止装置，可以用于紧急停止。

When installing more than one machine of this kind, the electrical system must be designed and built so that each can be used separately without the other adjacent Robots constituting a hazard or hindrance to operators.

当安装此类多台机器时，电气系统必须进行设计和改造以使得每个工业机器人可以单独使用，而不会对相邻机器人构成危害或妨害操作员。

Install cabling in areas where there are no hazards of a mechanical nature (such as impact from vehicles like lift trucks).

安装布线应在没有机械性质危险（例如叉车的影响）的区域。

Make connections in a professional manner following the instructions given in section.

以专业的方式按照 1.3.4 节中给出的说明连接电源。

The power supply wires and earth cable must be connected directly to the top of the electrical cabinet's main switch.

电源线和接地线必须直接连接到电柜主开关的顶部。

The terminal for connecting the earth cable is coloured yellow and green.

用于连接地线的终端为黄绿色。

1.3Connections 连接

1.3.1 Transport 运输



To move the electrical cabinet, use a forklift truck to lift it off the pallet and place on the floor
移动电柜需要使用叉车将电柜托举离开托板并放置在地上。

Forklift load capacity, minimum 300Kg
叉车的负载最小为 300 千克。

Maximum width between forks: 700mm
叉头之间最大宽度：700 毫米

Figure5:Electrical Cabinet move with forklift
用叉车移动电柜



once placed on the floor, it can be used a pallet truck to move them and locate them in their final position

放置在地上可以使用托盘搬运车移动至并放置到最终的位置。

Figure6:Electrical Cabinet move with pallet truck
用托盘车移动电柜

1.3.2 Installation 安装



MANDATORY ACTION 强制性措施

The electrical cabinet must be placed outside the safeguarded space, i.e. the space defined by the perimeter safeguarding devices

电柜必须放置在外围有安全保护措施的区域，例如定义为外围保护装置。



MANDATORY ACTION 强制性措施

The electrical cabinet must not be placed outdoors

电柜不能放置在户外。

The electrical cabinet must be positioned so that the Robot can be seen when the operator is standing in front of the control panel

电柜必须定位，以方便当操作员站在控制面板前可以观测机器人。

Do not place anything in front of the electrical cabinet: always leave enough clear space in front of the electrical cabinet so that the control panel is always easy to reach

不要将任何物品放置在电柜前：保证电柜前有足够的空间以便可以容易触碰到控制面板。

The electrical cabinet must be kept locked at all times while the machine is being used, and the keys must be kept by the electrician

当机器正在运转中的任何时候，电柜必须保持锁住，并且钥匙必须由电工人员保管。

When positioning the electrical cabinet, bear in mind the spaces to be kept clear, which are marked with hatching.

In the forced ventilation version:

- to the left of the electrical cabinet as this is where the fan's air intake, USB and Ethernet ports are located
 - at the front, to allow the door to be opened
 - on the right to allow the door to open fully
- 当电柜固定位置时，牢记保持该区域整洁，标记在图中阴影部分。

强制通风的版本:

- 电气柜左边就是风扇的进气口，USB 和以太网端口位于该侧。
- 在前面，以允许打开门
- 在右边，让门完全打开

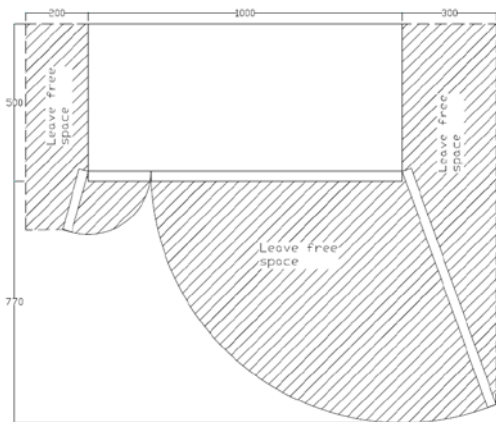
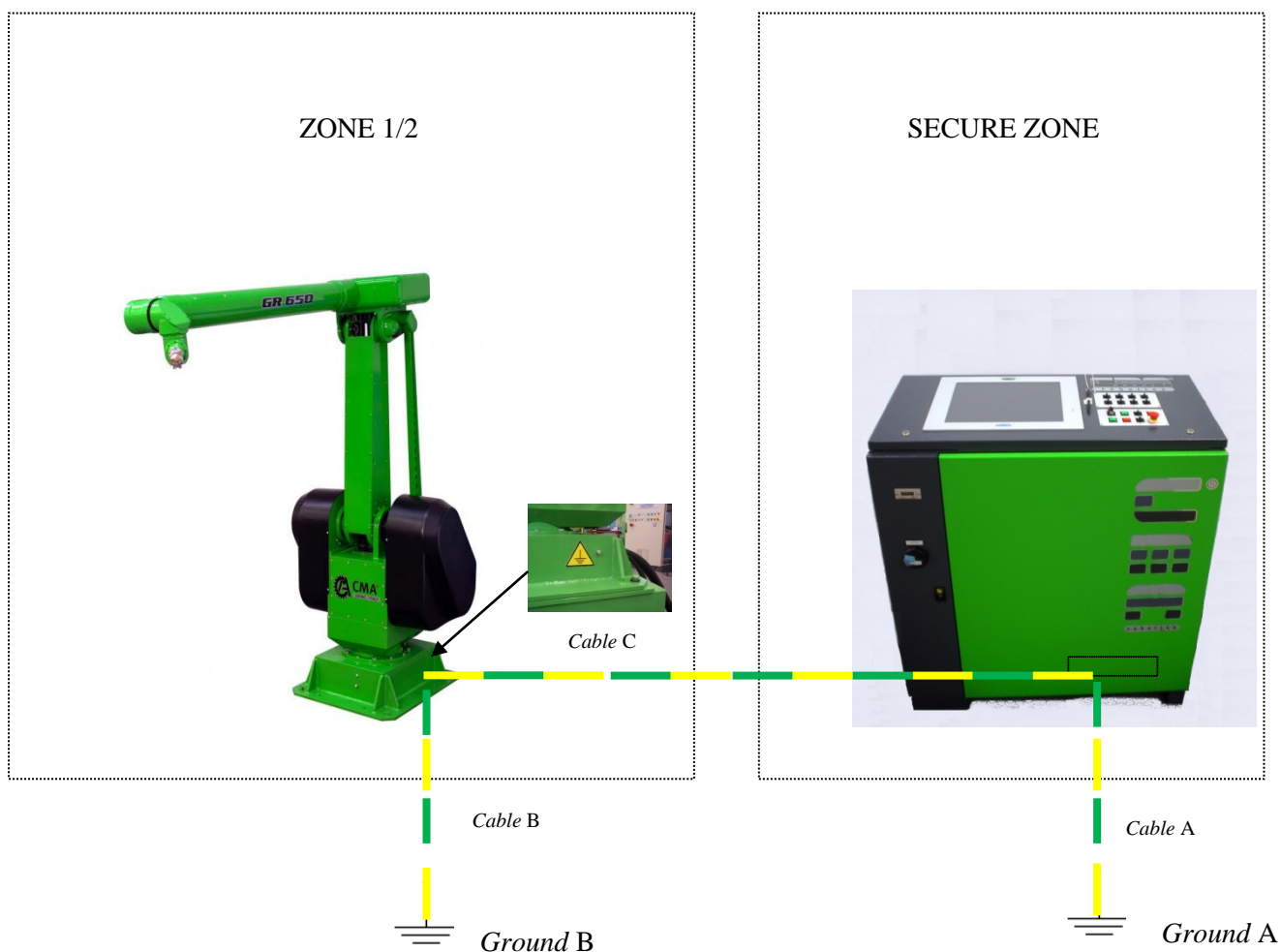

Figure7:Installation, version with forced ventilation
强制通风版本的安装

1.3.3 Connecting earth cables 地线连接



- Use a 10mm² yellow/green wire to connect the Robot body to an Earthing point (Cable B)
- 用 10 mm² 黄绿色电线将机器人本体连接到接地点（电缆 B）

Connect the electrical cabinet's earthing bar to an earthing point using a cable with a cross-sectional area of at least 2.5mm² in accordance with EN 60079 (CABLE A) 电柜的接地端和接地点使用的连接电缆横截面积至少为 2.5 mm² 且符合 EN 60079 标准（电缆 A）

1.3.3.1 Equipotential connection 等电位连接

Cable C comes fitted inside the Robot's cable sheathing. The end inside the Robot is already connected, the end inside the cabinet is connected by inserting the X3m plug of the robot-panel connecting cable into the X3f socket on the panel.

电缆 C 安装在机器人的电缆护套内，与机器人本体的末端已经连接。电缆与机柜内部的末端通过重载连接器 X3F 的插座和重载连接器 X3M 的插头连接。

1.3.3.2 . Equipotential connection GR NJ 16 等电位连接 GR NJ 16



MANDATORY ACTION

强制性的措施

The cable C is not contained in the set of supplied cables for connection between the electrical panel and Robot, it is therefore necessary to provide for connection of a yellow / green cable from 10mm², between the robot body and the equipotential bonding bar to inside the enclosure.

电缆 C 不包含在用于电控和机器人之间的连接电缆之内，在围栏内需要提供 10mm² 黄绿色电线连接机器人本体与等电位连接点。

1.3.4 Connecting to power supply 电源接线

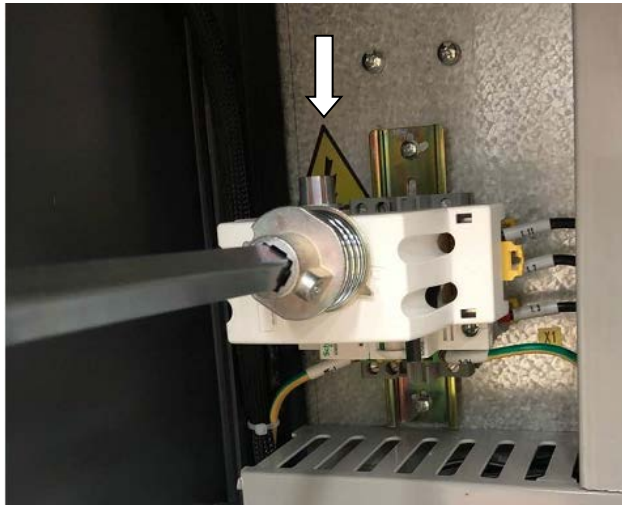

- Connect the power supply cable directly to the QS1 switch, the neutral wire is not needed
- Connect the yellow/green earth wire to terminal X1
- 电源线直接连接到 QS1 断路器上端，中性线不需要连接
- 黄绿色地线连接到 X1 接线端子

NOTA: The cross-sectional area of the wires must be at least 2.5mm²
注:导线的横截面积至少 2.5 mm²

Figure 8:Power supply connection
电源接线



MANDATORY ACTION 强制性的措施

All connecting wires (phases + earth) must be connected so that there is no chance of them being torn out or damaged in any way.

所有的连接线（相线+地线）必须连接，确保它们没有撕裂或任何损坏。More specifically, the power cord must be located in an area where it is not going to be run over by vehicles and lifting equipment, which could cut or damage the wire's insulation under their weight as they are being operated, or get caught on the actual cable and tear it out, which would present a serious electrocution hazard.

更具体地，电源线必须位于没有车辆和起重设备运行的区域中。若在有车辆和起重等设备区域中，设备运行时这些负荷会导致线缆的切断以及绝缘层的损害，或扯到实际电缆甚至拉断，这将带来严重的触电危害。

Feed the power cable in from the top inside ducting providing protection from damage of a mechanical nature or inside cable raceways in the ground.

1.3.4.1 Selection of the supply voltage (version with transformer) 隔离变压器的选择(隔离变压器版本)

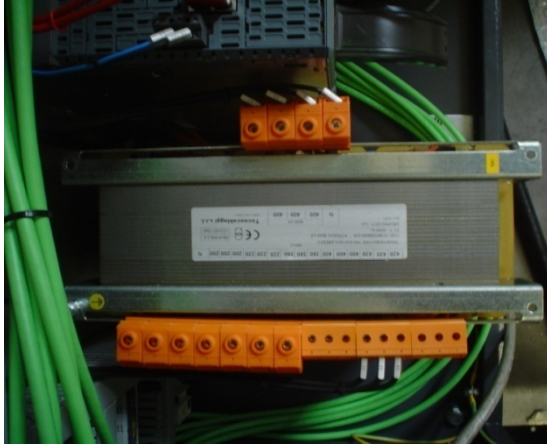

Figure9:Connecting to the power
电源连接

- Select the primary winding on the T21 transformer that best suits the available mains voltage. To do this, move the set of three wires 2.2, 2.5, 2.8 onto the terminals marking the most suitable voltage, choosing from 200, 220, 380 ,400 and 415V
- 在 T21 变压器选择初级绕组上最适合的可用电源电压。要做到这一点，将一组三根电线 2.2, 2.5, 2.8 连接到终端标记最合适电压的端子，从 200, 220, 380, 400 和 415V 中选择



MANDATORY ACTION 强制性措施

Transformer must be used in IT mains (neutral not connected to the earth) or TN-S mains with grounded phase conductor and protective ground conductor.
变压器必须使用 IT 接地系统（中性线不接地）或者使用有接地和保护接地的 TN-S 接地系统

1.3.5 Connecting the pendant (only PTP version)示教器的连接（PTP 版本）



Figure100:Connecting the pendant
连接示教器

Only with the PTP version cabinet
适用于 PTP 版本的电柜

- Connect the pendant's red cable to the socket on the door on the cabinet front.
- 将示教器的红色电缆连接到机柜门上的插座.

1.3.6 Connecting the Robot 连接机器

1.3.6.1 Connecting models 机型的连接



Figure111:Connecting the Robot
连接机器人

- Connect the motor feedback cables (green) to the relevant connectors on top of the drives, as specified in greater detail below.
- 编码器线(绿色)连接到驱动器顶部的相应接线端子,下面有更详细的规定。

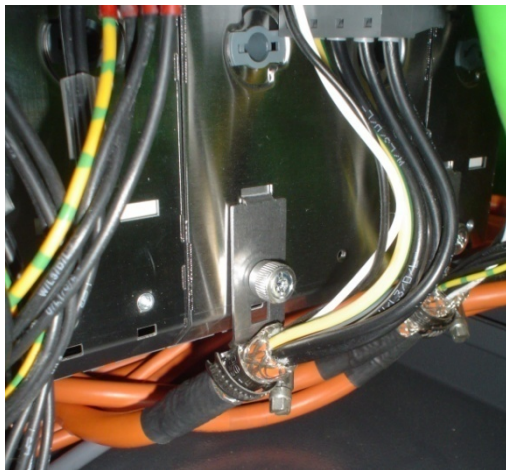

Figureq122:Connecting the Robot
连接机器人

- Connect the Robot's motor cables (orange) as illustrated and as specified in greater detail in tables 2, 3, 4 and 5 below.
- Fix the cable to the drive with the appropriate clamp, making sure there is contact between the shielding and the cable tie
- Also connect the axis 4-5-6 brake cable F2 to the X4 connectors (for models 650-6100 only) as specified in greater detail in tables 2, 3, 4 and 5 below.

- 机器人的动力线（橙色）见插图，详细介绍见表 2、表 3、表 4 和表 5。
- 驱动器的动力线固定在驱动器的锁紧箍，确保电缆的屏蔽层和锁紧箍可靠连接。
- 4-5-6 轴的抱闸线 F2 连接到 X4 接线端子（使用与型号 650-6100），详细介绍见表 2、表 3、表 4 和表 5。



Figure133:Connecting the Robot 连接机器人

- Connect the Signals cable to connector X3f on the electrical cabinet.
- 信号线与柜内 X3f 连接。



Signals cable connected.

By connecting this connector, the earth connection between the electrical cabinet and the robot is guaranteed, as described in paragraph

信号线的连接。连接此重载连接器，保证电柜和机器人之间的地线连接，如 1.3.3 段落地线的连接所述

Figure 144: Connect the Robot
连接机器人

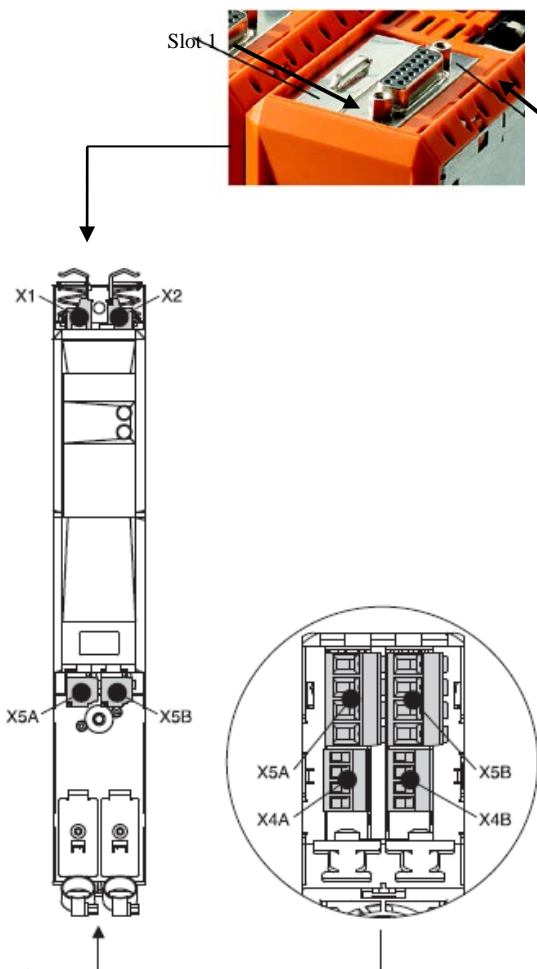

The Robot's drives can control one or two axes.

"Double" drives have two connectors for the motors and two connectors for the brakes.

Slot 2 The motor connectors are X5A and X5B. The brake connectors are X4A and X4B. There are also two slots for inserting the motor feedback I/O module

机器人的伺服驱动器可以控制一到两个轴。

双通道伺服驱动器有两套接线端分别连接两个电机和抱闸的接线端子。

伺服电机端子 X5A 和 X5B。

抱闸端子 X4A 和 X4B。

另两个插槽用于插入电机反馈 I/O 模块。

Figure 155: Connecting the Robot 连接机器人

The following tables specify the cable connections to the respective Drives The tables differ according to the panel model, number of axes and Robot model.

下表中指定电缆连接到相应的驱动器。根据面板类型、轴的数量和机器人型号的不同，表格的内容也不相同。

Models:GR630-650 ST (6 axes)								
Drive 驱动器	GF41		GF81		GF121			
	X5A	X5B	X5A	X5B	X5A	X5B		
Motor cable 电机电缆	M1	M2	M3	M4	M5	M6		
	X4A	X4B	X4A	X4B	X4A	X4B		
Brake cable 抱闸电缆				F2(1,2))	F2(3,4)	F2(5,6)		
	Slot1	Slot2	Slot1	Slot2	Slot1	Slot2		
Feedback cable 反馈电缆	E1	E2	E3	E4	E5	E6		

Table1: Drive Connections for GR630-650 ST (6 axes) 表 2: GR630-650 ST (6 axes)驱动器连接

Models: GR630-650 ST + RP (7 axes)								
Drive 驱动器	GF41		GF81		GF121		GF141	
	X5A	X5B	X5A	X5B	X5A	X5B	X5	
Motor cable 电机电缆	M1	M2	M3	M4	M5	M6	M7	
	X4A	X4B	X4A	X4B	X4A	X4B	X4	
Brake cable 抱闸电缆				F2(1,2))	F2(3,4)	F2(5,6)		
	Slot1	Slot2	Slot1	Slot2	Slot1	Slot2	Slot1	Slot2
Feedback cable 反馈电缆	E1	E2	E3	E4	E5	E6	E7	

Table2: Drive Connections for GR630-650 ST + RP (7 axes) 表 3: GR630-650 ST + RP (7 axes)驱动器连接

Models:GR630-650 G (8 axes)								
Drive 驱动器	GF41		GF81		GF121		GF161	
	X5A	X5B	X5A	X5B	X5A	X5B	X5A	X5B
Motor cable 电机电缆	M1	M2	M3	M4	M5	M6	M7	M8
	X4A	X4B	X4A	X4B	X4A	X4B	X4A	X4B
Brake cable 抱闸电缆				F2(1,2)	F2(3,4)	F2(5,6)		
	Slot1	Slot2	Slot1	Slot2	Slot1	Slot2	Slot1	Slot2
Feedback cable 反馈电缆	E1	E2	E3	E4	E5	E6	E7	E8

Table3: Drive Connections for GR630-650 G (8 axes) 表 4: GR630-650 G (8 axes)驱动器连接

Models: GR630-650 C (with Translation Carriage Y axis)								
Drive 驱动器	GF41		GF81		GF101		GF121	
	X5A	X5B	X5A	X5B	X5A	X5B	X5	
Motor cable 电机电缆	M1	M2	M3	M4	M5	M6	M9	
	X4A	X4B	X4A	X4B	X4A	X4B	X4	
Brake cable 抱闸电缆				F2(1,2)	F2(3,4)	F2(5,6)		
	Slot1	Slot2	Slot1	Slot2	Slot1	Slot2	Slot1	Slot2
Feedback cable 反馈电缆	E1	E2	E3	E4	E5	E6	E9	

Table4: Drive Connections for GR630-650 C(with Translation Carriage Y axis) 表 5:
GR630-650 C（带行走轴）驱动器连接

01-QE-0301/xx panel:

Drive 驱动器	GF41		GF81		GF101		GF121	
	X5A	X5B	X5A	X5A	X5B	X5		
Motor cable 电机电缆	M1	M3	M2	M4	M5	M6		
	X4A	X4B	X4A	X4A	X4B	X4		
Brake cable 抱闸电缆	M1	M3	M2	F2(1,2)	F2(3,4)	F2(5,6)		
	Slot1	Slot2	Slot1	Slot2	Slot1	Slot2	Slot1	Slot2
Feedback cable 反馈电缆	E1	E3	E2		E4	E5	E6	

Model: GR6160 ST + RP (7 axes)										
Drive 驱动器	GF41		GF81		GF101		GF121		GF161	
	X5A	X5B	X5A	X5A	X5B	X5	X5			
Motor cable 电机电缆	M1	M3	M2	M4	M5	M6	M7			
	X4A	X4B	X4A	X4A	X4B	X4	X4			
Brake cable 抱闸电缆	M1	M3	M2	F2(1,2)	F2(3,4)	F2(5,6)				
	Slot1	Slot2	Slot1	Slot2	Slot1	Slot2	Slot1	Slot2	Slot1	Slot2
Feedback cable 反馈电缆	E1	E3	E2		E4	E5	E6		E7	

Table5: Drive Connections for GR6160 ST + RP (7axes) 表 6: GR6160 ST + RP (7axes)驱动器连接

Model: GR6160 C (with Translation Carriage Y axis)										
Drive 驱动器	GF41		GF81		GF101		GF121		GF141	
	X5A	X5B	X5A	X5A	X5B	X5	X5		X5	
Motor cable 电机电缆	M1	M3	M2	M4	M5	M6	M9		M9	
	X4A	X4B	X4A	X4A	X4B	X4	X4		X4	
Brake cable 抱闸电缆	M1	M3	M2	F2(1,2)	F2(3,4)	F2(5,6)				
	Slot1	Slot2	Slot1	Slot2	Slot1	Slot2	Slot1	Slot2	Slot1	Slot2
Feedback cable 抱 闸电缆	E1	E3	E2		E4	E5	E6		E9	

Table6: Drive Connections for GR6160 C (with Translation Carriage Y axis) 表 7: GR6160 C (带行走轴) 驱动器连接

1.3.6.2 Connection models GR NJ 16 (control box 330)GR NJ 16 (控制盒 330)机型的连接

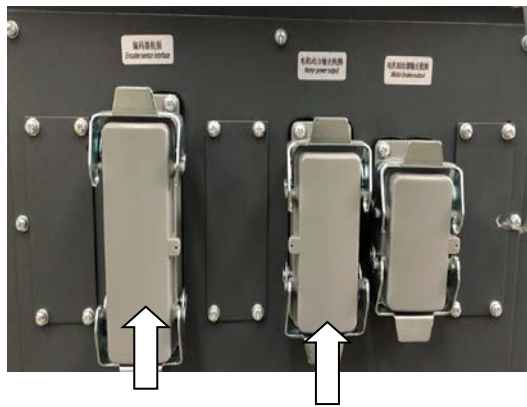

Figure 16:Connecting the Robot
连接机器人

Connect the motors cable and encoder cable to the two connectors Motors connector and power connector

将电机电缆和编码器电缆连接到动力航插和编码器航插两个连接器



Figure 17:Connecting the Robot
连接机器人

If present connect also the signal cable X3f

当前信号线 X3f 是否也连接

1.3.7 Connecting safety devices 安全设备连接

1.3.7.1 Connecting a door safety switch in one Robot with Mobile Panel 安全门开关连接在有移动面板的机器人



Figure18:Perimeter protection
周边保护

The electrical cabinets can accommodate safety switches to be fitted on the safety doors of perimeter protection preventing access to the Robot's work area.

电气柜可容纳安装在防护门防止进入机器人的工作区的安全开关。

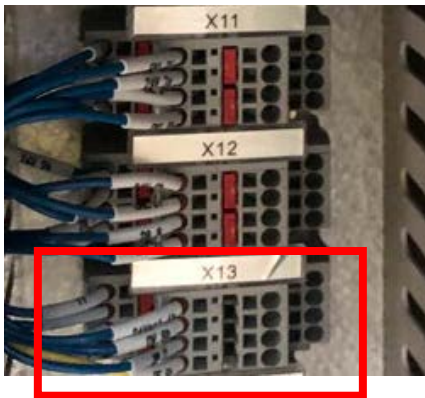

Figure19 :Terminal safety switch
安全门开关端子

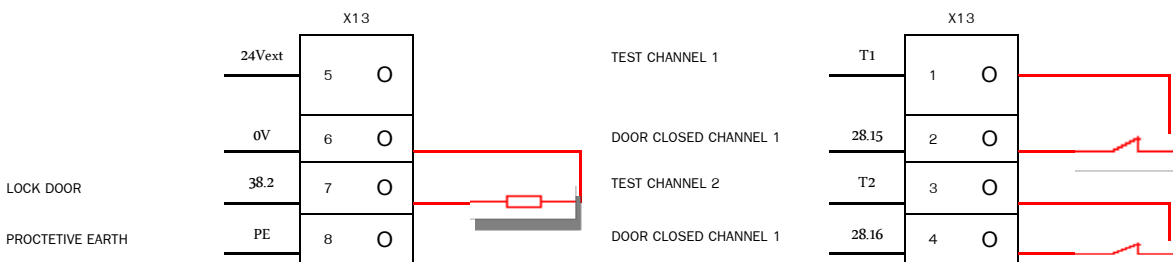

Table 7: Terminal door's safety switch 表 8:安全门开关端子

Connect the two contacts of the safety switch to terminals 1, 2 and 3, 4 of the terminal block X13. 安全门开关的两路常闭触点分别连接到 X13 接线端子的 1、2 和 3、4。

It 'also provided an' exit door lock that is activated once you start the automatic cycle of the machine .If the safety switch is equipped with electronic lock allows you to lock the door of

access to the 'workspace. The output for the door lock delivers a maximum current of 0.5A. It is possible to power auxiliary signaling devices between terminals 5 and 6 (24V, 1A).

一旦机器人开始自动循环，安全门锁紧信号被激活。如果安全开关配有电子锁，可以锁住进入工作区的入口。门锁的输出需要提供 0.5A 的最大电流。由接线端子 5、6（24V，1A）作为辅助供电端子。



MANDATORY ACTION 强制性措施

To enable the machine to work in automatic mode, a safety circuit must be connected to the terminal X13

使机器处于自动模式下工作，安全电路必须连接到端子 X13



Figure 17: Connecting a safety switch
连接安全开关

On direct teaching models GR630 and GR650, the operating mode selector on the electrical cabinet's control panel AUTO – TEACH automatically selects the suitable safety device.

in automatic model, the safety switch is enabled, while in TEACH mode, the safety switch is disabled to allow access to the Robot work area. In this mode, the pendant's Enable switch allowing movement is ON.

在 GR630 和 GR650 的直接示教模式下，在电柜的控制面板 AUTO – TEACH 操作模式选择 - 自动示教选择合适的安全设备。

在自动模式中，安全开关被接通，而在示教模式中，安全开关被禁用以允许进入所述机器人的工作区域。在这种模式下，示教盒的允许运动的时能开关状态为 ON。

1.3.7.2 Connecting door safety switch in one Robot without Mobile Panel 无移动面板的机器人上连接安全门开关



MANDATORY ACTION 强制性措施

In applications where the Mobile Panel is not expected, connect the two normally closed contacts of the safety switch to terminal block X12 of Mobile Panel Emergency, not being necessary the exclusion of the same switch in the machine learning mode (TEACH).

示教盒不能涉及的应用场所，连接两路安全门开关的常闭触点到示教盒急停的 X12 的接线端子，在机器人示教模式下不需要排除同一开关（TEACH）。

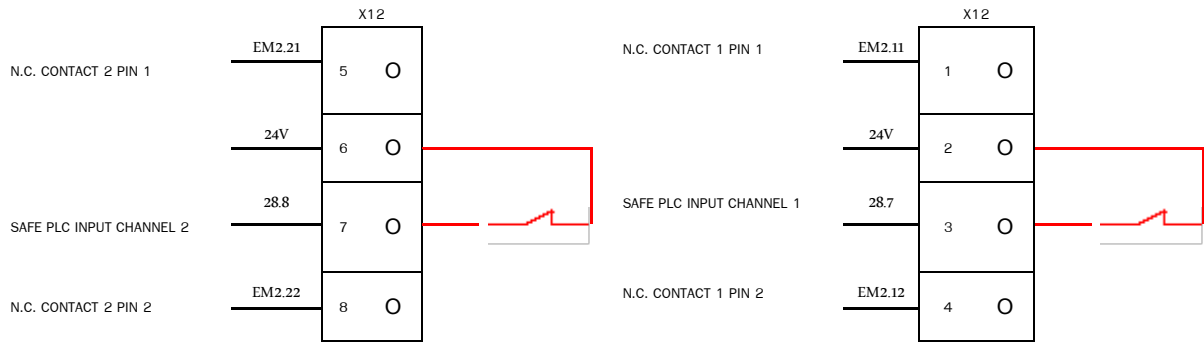
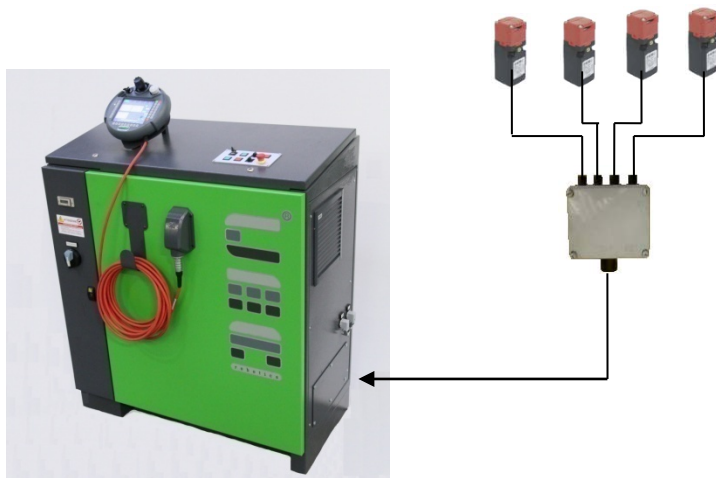

Table 8: Mobile Panel's Emergency terminal block (function safety door) 表 9 示教盒的紧急接线盒(功能安全门)

1.3.7.3 Connecting a number of door safety switches 连接多个安全门开关



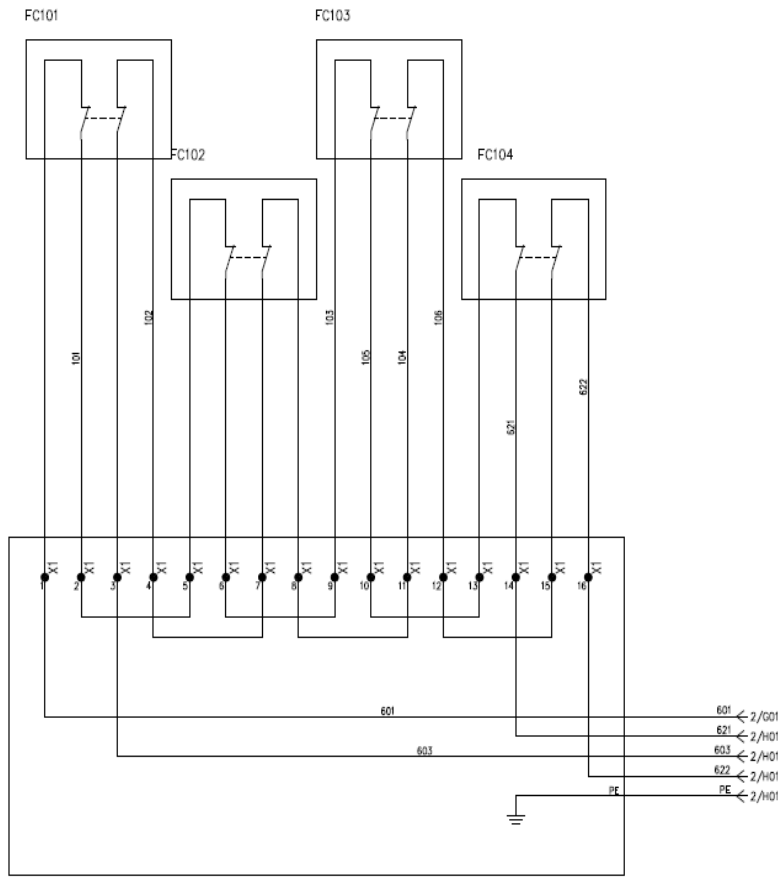

Figure20:Connecting a number of safety switch
多个安全门开关的连接

The diagram on the left shows an example of how four door safety switches can be connected.

The four switches are conveyed to a junction box where the two contacts for each individual switch are connected in series via a terminal block.

The result of the serial connection is connected to the X13 or X11 terminal block, see previous paragraph.

左边的图显示了四个安全门开关如何连接的例子。这四个开关被连接到一个接线盒，每组常闭触点被分别串联到相应的两组接线端子上。最后串联连接的信号被连接到 X13 或 X11 的接线端子，参考前面的段落连接。

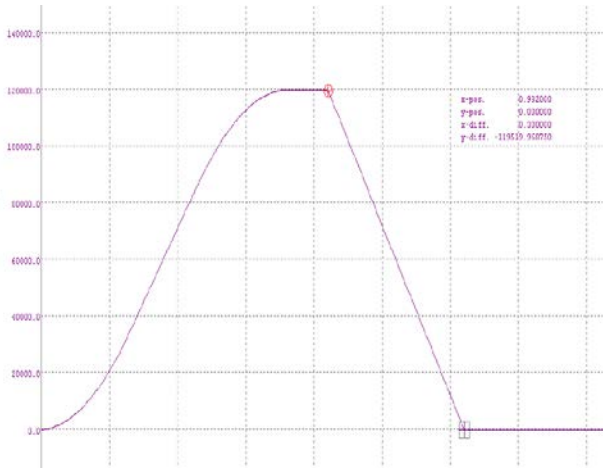

Figure 182: Graph showing Controlled stop time for axes 1, 2, 3
1、2、3 轴停止控制时间图

The light curtain can be positioned the following distance from the Robot work area:

光幕可以置于以下距离到机器人工作区：
 $S = K (t_1 + t_2) + C$

As prescribed by UNI EN ISO 13855:2010. 根据 UNI EN ISO 13855:2010 的规定。

Where: 这里:

- K = Speed at which person approaches hazardous zone、人接近危险区域的速度
- t1 = light curtain system + control unit tripping time 光幕系统+控制单元反映时间
- t2 = Robot stopping time 机器人停止时间
- C = 850 with resolution > 40mm
otherwise C = 8(d \square - 14) con \square = de \square ice resolution.

The Robot stopping time t2 is 0.3 s. on 机器人停止时间 t2 为 0.3 秒。

1.3.7.5 Choosing safety devices, assessing overall Performance Level. 选择安全设备, 评估整体安全等级

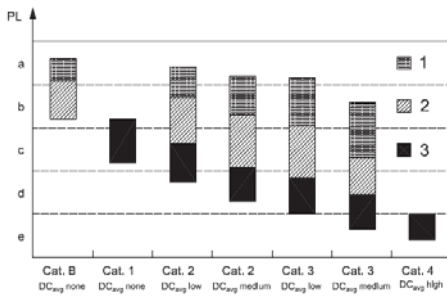

Figure 23 Choosing safety devices
选择安全设备

The Industrial Robot standard UNI EN ISO 10218-1:2009 calls for safety circuits to meet at least category 3 standards, according to UNI EN ISO 13849-1:2008, or for the safety circuit's Performance Level to be no less than the minimum prescribed for this category, hence no less than "d".

根据 UNI EN ISO 13849-1: 2008, 工业机器人标准 UNI EN ISO 10218-1: 2009 要求的安全电路至少满足 3 类标准, 或安全电路的性能水平不低于最低规定的安全等级, 因此不能小于 "d"

To assess the Performance Level, we need to take into consideration the three main blocks of a safety circuit.

为了评估性能水平，我们需要考虑到安全电路的三个主要模块。

- I = input block 输入块
- L = control logic 控制逻辑
- O = output device 输出设备

Blocks L and O are inside the electrical cabinet. Block L is the safety PLC. Block O comprises safety relays and Robot drives. The Performance Level of the safety PLC is rated "e", while that of the drives with the safety relays reaches level "d". 块 L 和 O 是在电柜内。块 L 是安全的 PLC。O 模块由安全继电器和机器人驱动器组成。当有安全继电器的驱动器性能水平达到"d"等级时，安全 PLC 的性能等级为"e"。

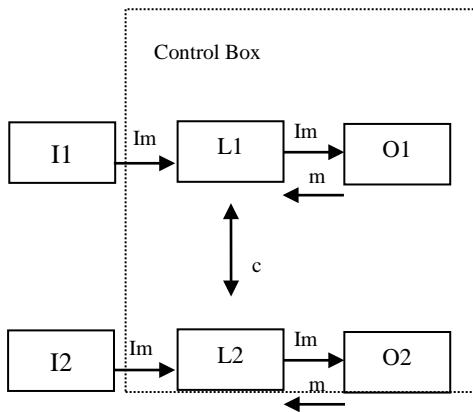

Figure 19: Choosing safety devices
选择安全设备

	I		L		O
PL	?		□		□

PL _{low}	N _{low}	⇒	PL
a	> 3	⇒	None, not allowed
	≤ 3	⇒	a
b	> 2	⇒	a
	≤ 2	⇒	b
c	> 2	⇒	b
	≤ 2	⇒	c
d	> 3	⇒	c
	≤ 3	⇒	d
e	> 3	⇒	d
	≤ 3	⇒	e

NOTE: The values calculated for this look-up table are based on reliability values at the mid-point for each PL.

Figure 20: Choosing safety devices
安全等级选择

Once we know the Performance Level of the input device we want to use, we can use the table on the left to determine the overall Performance Level (PLr) of the safety circuit by proceeding as follows:

一旦我们知道我们想要的输入设备的性能水平，我们可以使用左边的表来确定安全电路的整体性能水平(PLr)，按如下流程：

Identify the lowest of the three PLs

确定最低的三个 PLs

Identify the number of blocks with this PL

确定这种 PL 块的数量

Find the PLr in the table on the left

在左边的表中查找 PLr

It follows that for PLr to equal d, the input device chosen must have a PL of at least d

它遵循 PLr 等于 D 时，所选择的输入装置必须至少为 d 的 PL

1.3.7.6 Connecting to the Emergency stop circuit .连接到紧急停止电路

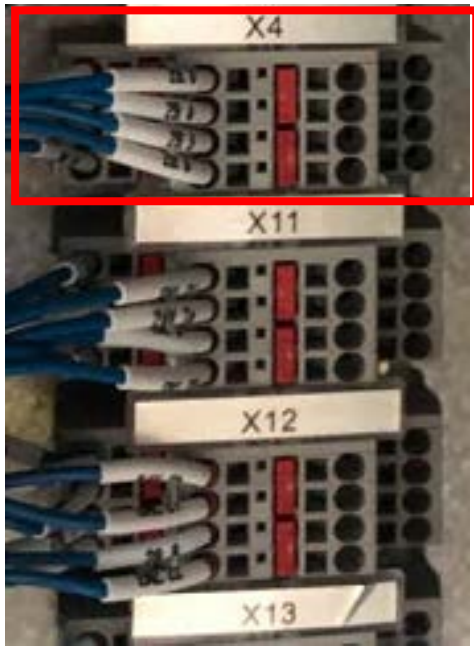

Figure 26 Connecting to emergency circuit
急停回路的连接

The photo shows the location of the X4 terminal block.

The Robot's emergency stop circuit meets category 3 standards.

For this reason, wiring involves two contacts.

The Robot can behave as wither a Master or Slave when inserted in a system. Hence there is provision both for an input to switch the Robot to emergency mode (Slave mode) and for an output to switch the system's other cabinets to emergency mode when a mushroom-head emergency stop button is pressed on the Robot (Master mode).

该图显示了 X4 接线盒的位置。

该机器人的急停电路符合 3 类安全等级标准。

出于这个原因，布线涉及两个干触点。

该机器人在系统中可以作为一个主站或从站。因此，这既是一个输入，切换机器人到急停模式（从站模式）；也是当机器人的急停按钮按下时，作为一个输出信号将系统的其他电柜切换到急停模式。（主站模式）

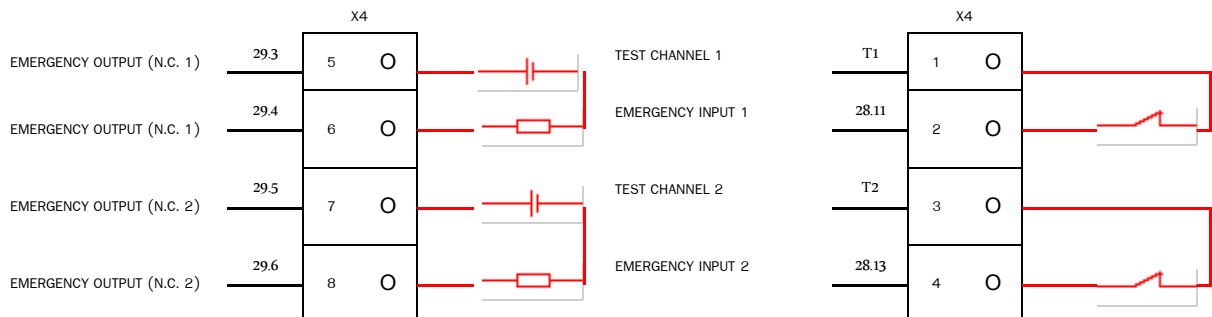

Table 9: Connection to the emergency circuit 表 10 :急停回路的连接

The first four terminals X4.1, X4.2, X4.3 and X4.4 are jumpered and are used to connect the additional mushroom-head Emergency stop buttons or emergency stop control from the system's other electrical cabinets (Slave mode).

前四个端子 X4.1、 X4.2、 X4.3 和 X4.4 是跳线且用于连接更多的急停按钮或来自系统的其他电柜的紧急停止控制（从属模式）。

The second four terminals X4.5, X4.6, X4.7 and X4.8 show the closed contact of two relays; the contacts open when the Robot is in emergency mode (Master mode).

第二排四个端子、 X4.6、 X4.7 和 X4.8 显示两个延时继电器闭合触点；机器人处于紧急模式（主模式）是，闭合的触点打开。



MANDATORY ACTION 强制性措施

Only one of the two modes must be used, otherwise special resetting operations must be provided externally to the Robot's control cabinet, or the Mobile Panel emergency and the cabinet emergency push buttons must be handled directly by the main control box of the whole system. See paragraph 06.3.7.7.External management emergency stop push buttons

只有两种模式中的一个能使用，否则特殊复位操作必须由机器人的电柜外部提供，或移动面板的急停和电柜上的按钮必须由整个系统的主控制柜直接处理。参见第 1.3.7.7 节外部管理急停按钮

1.3.7.7 External management emergency stop push buttons 外部管理紧急停止按钮



Inside the control box there are two terminal block for configuration/interface the mushroom emergency on the control box itself and the mushroom emergency on the mobile panel(if provided).

控制箱内部有两个接线端用于配置/交互电柜自身控制面板上和示教盒面板上的急停蘑菇头(如果有提供)。



Figure 27:Control box and Mobile Panel emergency
控制盒和示教盒的急停

The emergency button on the control box is managed by the safety PLC inside itself when the configuration jumpers are setas the following table(standard configuration):

由安全 PLC 内部程序管理电柜的紧急按钮，配置的跳线设置如下表（标准配置）：

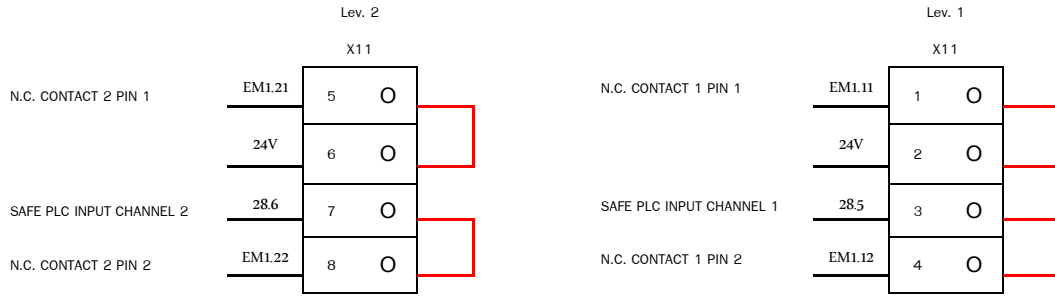

Table 10: Terminal block for main panel emergency button (internal management) 表 11: 主控制面板上急停按钮的接线端子 (内部接线)

By placing configuration jumpers as the following table it becomes possible to manage the emergency stop of the robot control box directly from the main control box of the whole system used as monitoring of emergencies where the robot has been entered.
根据下表配置跳线就可以实现整个系统的主电柜直接响应机器人电柜的急停，以此用作监测机器人已经进入的急停。

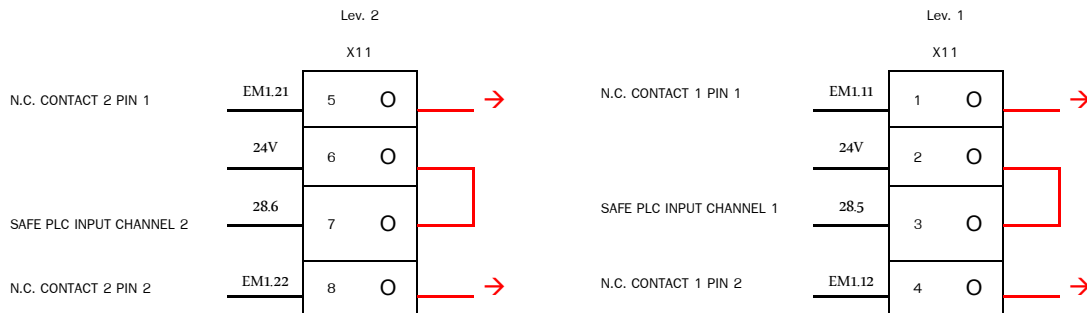

Table 11: Terminal block for main panel emergency button (external management) 表 12: 主控制面板上急停按钮的接线端子(外部管理)

On the terminals marked by the arrow are made available two normally closed contacts of the emergency button on the control box main panel.
在终端上的箭头标记表示在控制箱的主面板上急停按钮的两个常闭接触点。
As described for the emergency button on the main control panel we have the following standard configuration for the emergency button on the Mobile Panel
主控制面板上的急停按钮，在示教盒上急停按钮我们有以下标准配置

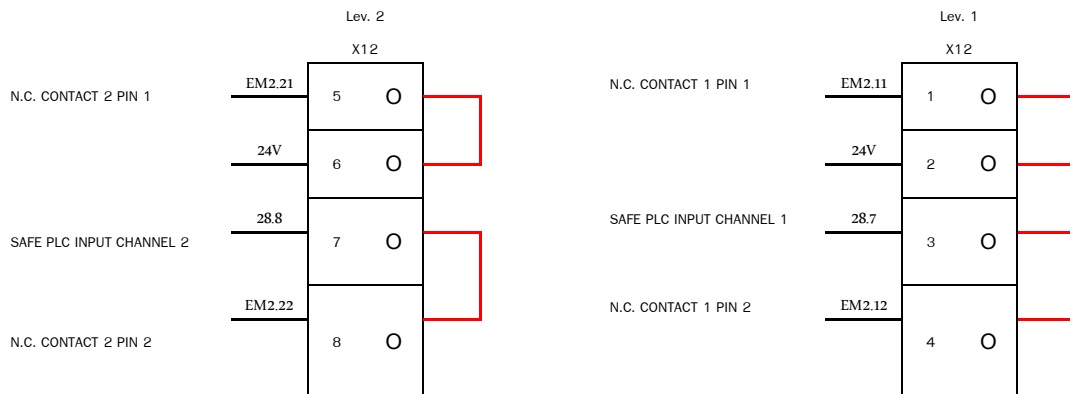

Table 12: Terminal block for Mobile Panel emergency button (internal management) 表 13: 移动面板紧急按钮的接线端子(内部接线)

While to manage the Mobile Panel emergency button from external the configuration jumpers is as follows:

管理来自外部配置跳线的示教盒上的急停按钮，如下所示：

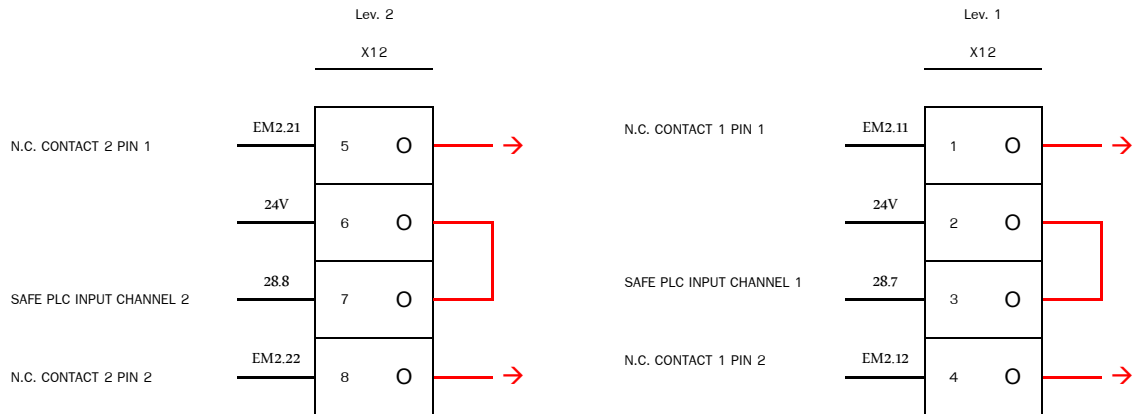
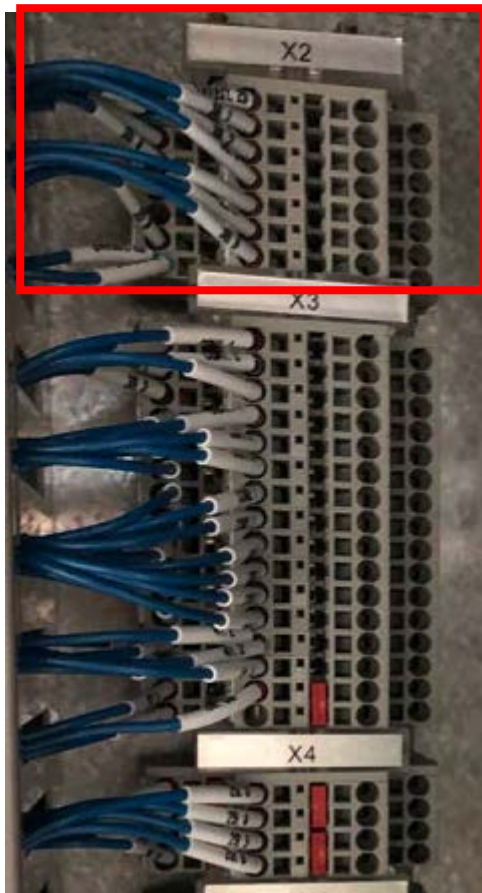

Table 15: Terminal block for Mobile Panel emergency button (external management) 表 15: 示教盒急停按钮的接线端子(外部接线)

1.3.8 Available input signals (X2)可用的输入信号 (X 2)



The photo shows the location of the X2 terminal block.

To enable an input it is necessary to close the circuit between COMMON n and the desired input terminal. All COMMON terminals are 24V

这张照片显示了 X2 接线端子排的位置。
启用一个输入口必须关闭公共端 n 和所需的输入终端之间的回路。
所有公共端接入 24V。

.Figure21.Connecting the input signals
输入信号连接

The following standard signals are available on terminal block X2:
以下标准信号为 X2 端子排上的可用信号：

X2.1	公共端 1	Common for terminals 2, 3 and 4 (24V) 公共端子 2, 3 及 4 (24V)
X2.2	GUN 2 SELECTION	Selects gun number 2 选择枪 2
X2.3	FREE 空闲	
X2.4	FREE 空闲	
X2.5		
X2.6	ENABLE TURN TABLE ROTATION	Input for enabling carousel rotation in G versions 输入用于启用 G 版本的旋转工作台
X2.7	公共端 2	Common for terminal 5 (24V)通用端子 5 (24V)
X2.8	公共端 3	Common for terminals 7,8,9,10,11,12,13 (24V) 通用端子 7,8,9,10,11,12,13 (24V)
X2.9	REMOTE START	Signal for starting a robot work cycle, used in G versions and in ST versions with conveyor in step mode 用于启动机器人工作周期的信号，应用在 G 版本中，并在 ST 版本中用于输送机的步进模式
X2.10	START FROM CONVEYOR	Signal for starting a robot work cycle, used in ST versions with conveyor in continuous mode 启动机器人工作周期的信号，用于 ST 版本中输送机的连续模式
X2.11	CONVEYOR STEP/CONTINUOUS	In the event the conveyor can work in both step and continuous operating modes, the signal serves to advise the Robot which of them is being used. 如果输送机可以在单步和连续操作模式工作，该信号用于判断哪些机器人正在被使用中。
X2.12	CONVEYOR IN POSITION	Signal showing the conveyor is in position and the painting cycle can be started 该信号表示的输送机已经到位，且喷涂周期可以开始
X2.13	BAR ROTATION COMPLETED	Signal showing the rotation of the bar has been completed and painting of the back can be started 该信号表示在旋转杆已经就位，且喷涂背面可以开始
X2.14	START WASHING	Input used to book a washing cycle at the end of the program in progress, in automatic operating mode 该输入用来在正在进行的程序结尾预置清洗周期，且在自动运行模式下

Table 13: Input signals 表 14: 输入信号

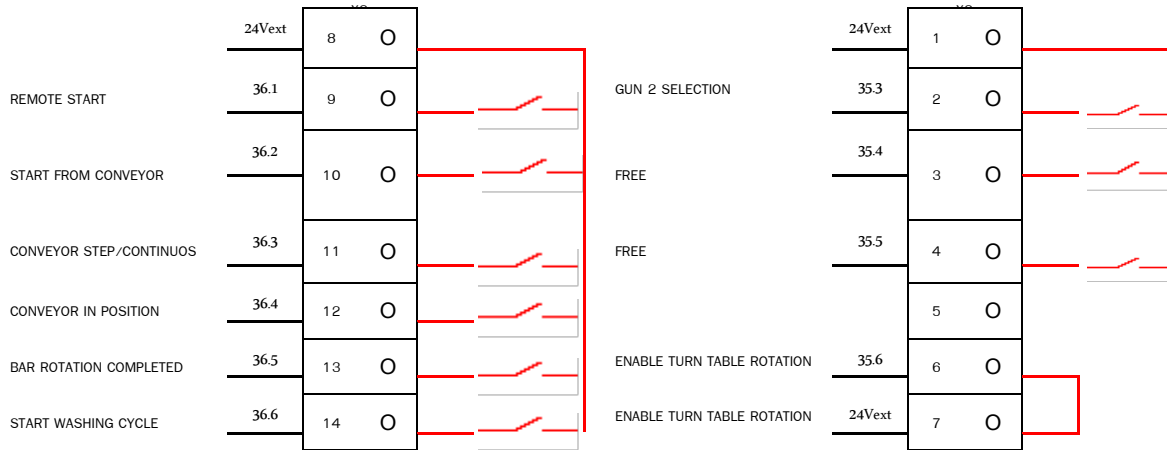

Table 14: Input signals connection 表 15: 输入信号连接

1.3.9 Available output signals (X3)可用输出信号 (X3)

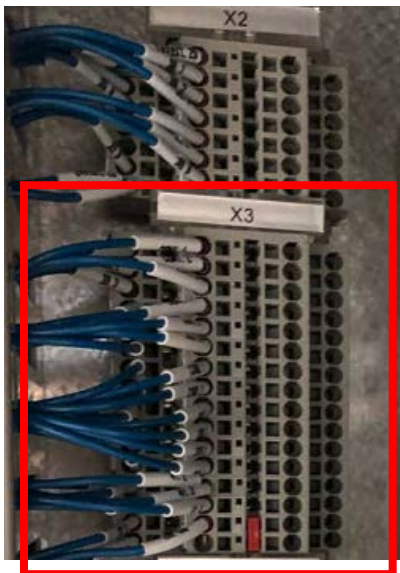

Figure29: Connection of output
输出信号连接

The photo shows the location of the X3 terminal block
The output are free potential normally open contacts
115V AC 0,5A or 30V DC 1A.

这张照片显示了 X3 接线端子排的位置
输出端是无电位的常开接触端 115 v AC 0,5 1 或 30 v DC。

The following standard signals are available on terminal block X3:
以下标准的可用信号在端子排 X3 上

X3.17	COMMON 1	Common for terminal 1 (potential free)公共端子 1(无电位)
X3.1	ROBOT STANDBY	This signal indicates that the robot has reached the first point of the program and is standing by for a remote start 这个信号表示该机器人已达到程序的第一点以及用于远程启动
X3.18	COMMON 2	Common for terminal 2 (potential free)公共端子 2(无

		电位)
X3.2	ROBOT BUSY	Signal indicating that the robot's work list contains at least one program 信号表明机器人的工作列表包含至少一个程序
X3.19	COMMON 3	Common for terminal 3 (potential free)公共端子 3(无电位)
X3.3	PROGRAM IN PROGRESS	Indicates that execution of the work program is in progress 表明工作程序正在运行中
X3.20	COMMON 4	Common for terminal 4 (potential free)公共端子 4(无电位)
X3.4	CONVEYOR STEP	Request for conveyor step 请求输送步骤
X3.21	COMMON 5	Common for terminal 5 (potential free)公共端子 5(无电位)
X3.5	ROTATE BAR	Request for bar rotation 请求旋转杆
X3.22	COMMON 6	Common for terminal 6 (potential free)公共端子 6(无电位)
X3.6	WASHING POSITION	This signal indicates that the robot has reached the washing position 该信号表明机器人已经达到了清洗位置
X3.23	COMMON 7	Common for terminal 7 (potential free)公共端子 7(无电位)
X3.7	GUN 1 SELECTED	Gun 1 selected 选择枪 1
X3.24	COMMON 8	Common for terminal 8 (potential free)公共端子 8(无电位)
X3.8	GUN 2 SELECTED	Gun 2 selected 选择枪 2
X3.25	COMMON 9	Common for terminal 9 (potential free)公共端子 9(无电位)
X3.9	ROTATE PIECE AT HOME	If there is an axis for part rotation, this signal indicates that the rotate-piece device is in the zero degree position 如果有一个轴部的旋转，该信号指示该旋转件装置处于零度位置
X3.26	COMMON 10	Common for terminal 10 (potential free)公共端子 10 (无电位)
X3.10	FREE	Generic output 公共输出
X3.27	COMMON 11	Common for terminal 11 (potential free)公共端子 11 (无电位)
X3.11	FREE	Generic output 公共输出
X3.28	COMMON 12	Common for terminal 12 (potential free)公共端子 12 (无电位)
X3.12	FREE	Generic output 公共输出
X3.29	COMMON 13	Common for terminal 13 (potential free)公共端子 13

		(无电位)
X3.13	ENABLE CONVEYOR	Enabling signal for conveyor start 输送机开始启用信号
X3.30	COMMON 14	Comon for terminal 14 (potential free)公共端子 14 (无电位)
X3.14	ELECTROSTATIC DEVICE	Enabling signal for a piece of equipment to support the spraying device 单台设备的使能信号以支持所述喷涂设备
X3.31	COMMON 15	Common for terminal 15 (0V)公共端子 15(0 v)
X3.15	FREE	Generic output 公共输出
X3.32	COMMON 16	Common for terminal 16 (0V)公共端子 16(0 v)
X3.16	FREE	Generic output 公共输出
Table 15: Output signals (X3) 表 16: 输出信号 (X3)		

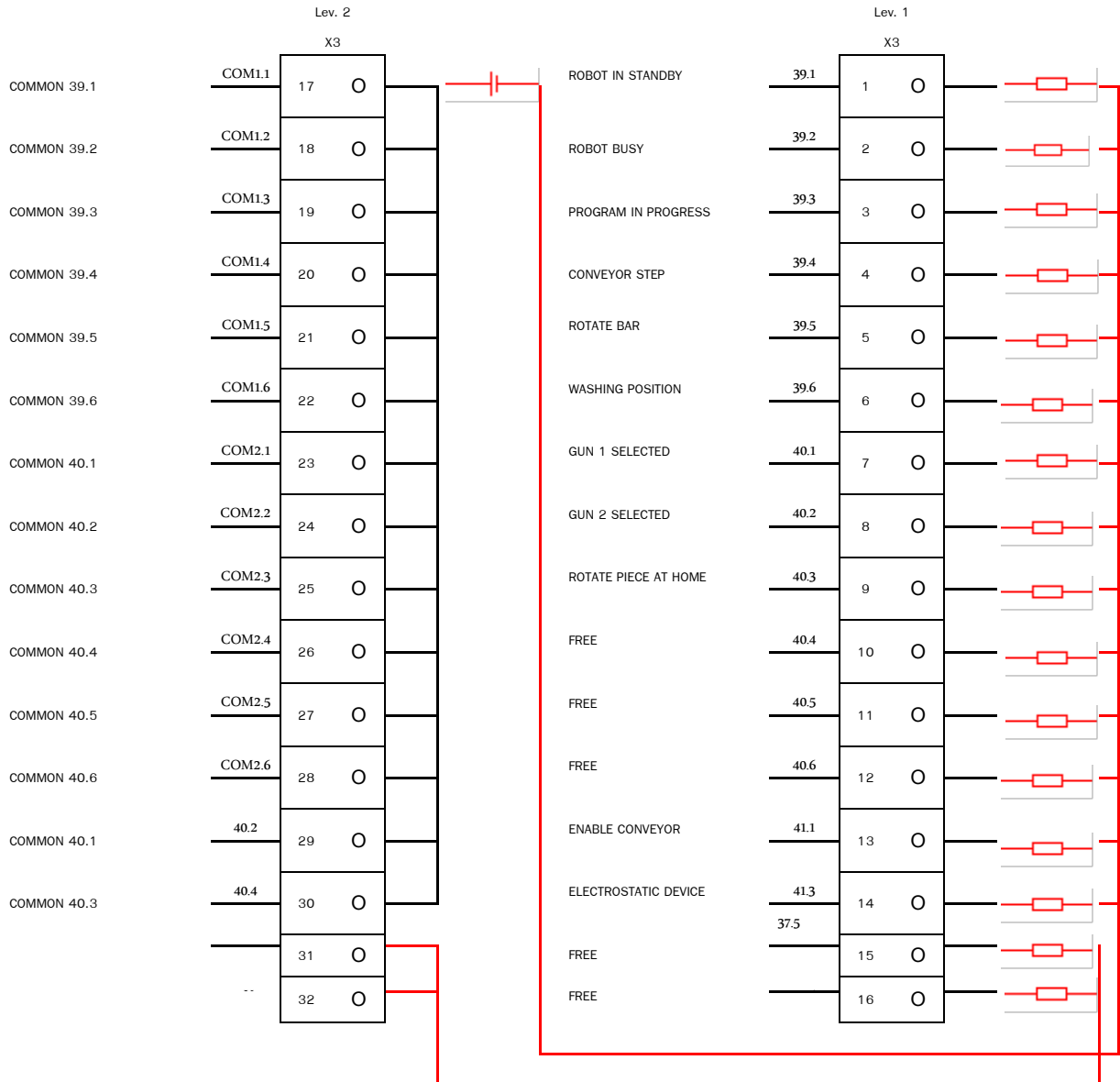
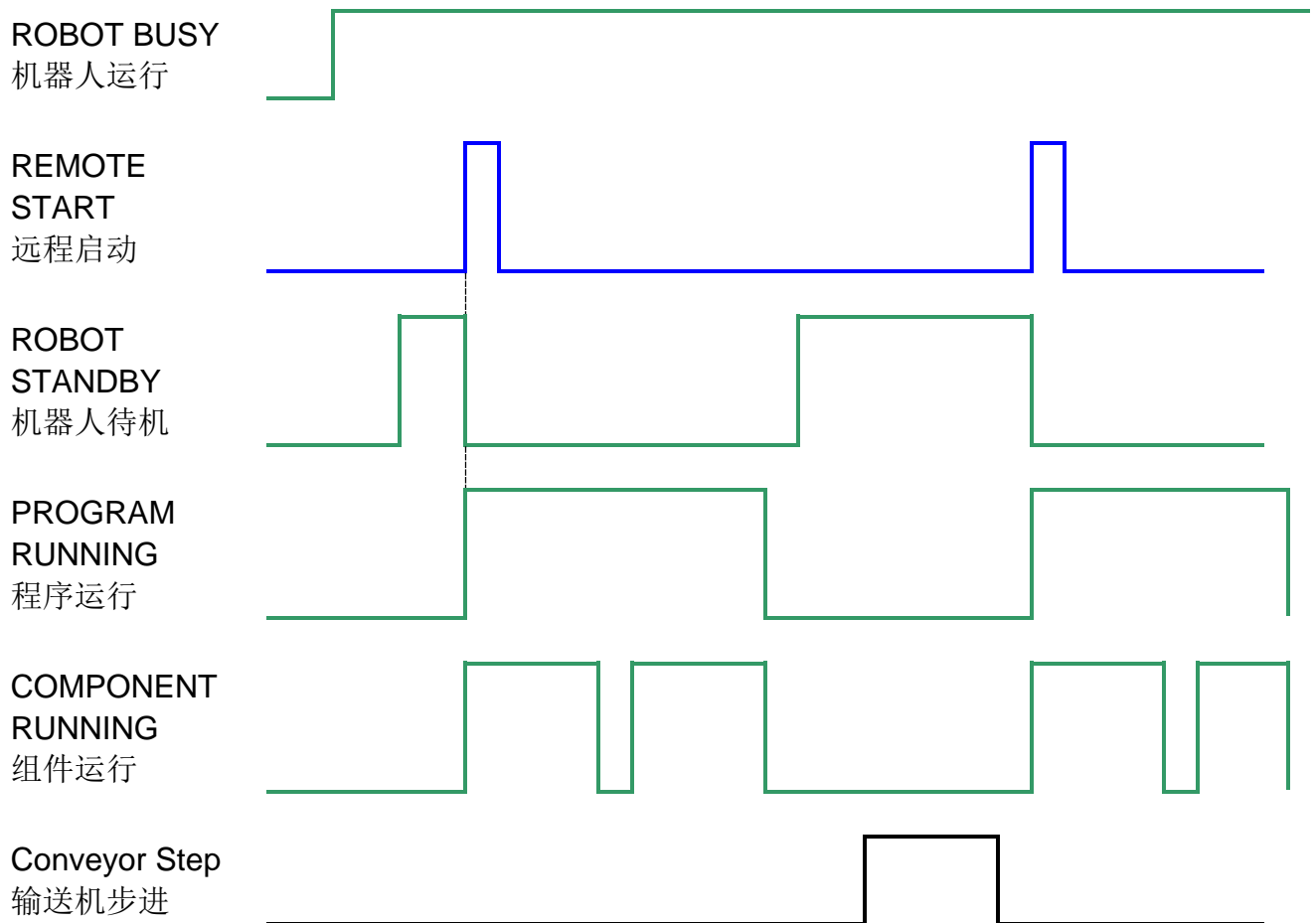

Table 16: Output signal connection 表 17 : 输出信号连接

1.3.9.1 Example of how available signals are used (time-based diagrams) 信号是如何使用的范例(基本时序图)

The following diagram shows a number of signals that can be used in the event the Robot is interfaced with a conveyor in step mode.

下图显示了机器人界面上的输送机在步进模式下使用的信号。



1.3.10 Connecting the start limit switch and encoder (PTP/APS versions) 连接启动限位开关和编码器（PTP / APS 版本）

To synchronize the Robot's speed with that of the conveyor, we need to measure the latter's speed.

This is done using an incremental encoder that will be mounted on the conveyor's drive unit and connected to the I/O module to be inserted in the I/O board assembly. A limit switch will also be fitted, whose purpose is to start the Robot's work cycle.

为了使机器人的速度与输送机同步，我们需要测量后者的速度。这里将增量编码器安装在输送机的驱动装置上，并连接到 I/O 模块以便插入 I/O 底座。同时还将安装限位开关，其目的是记录机器人的工作周期。

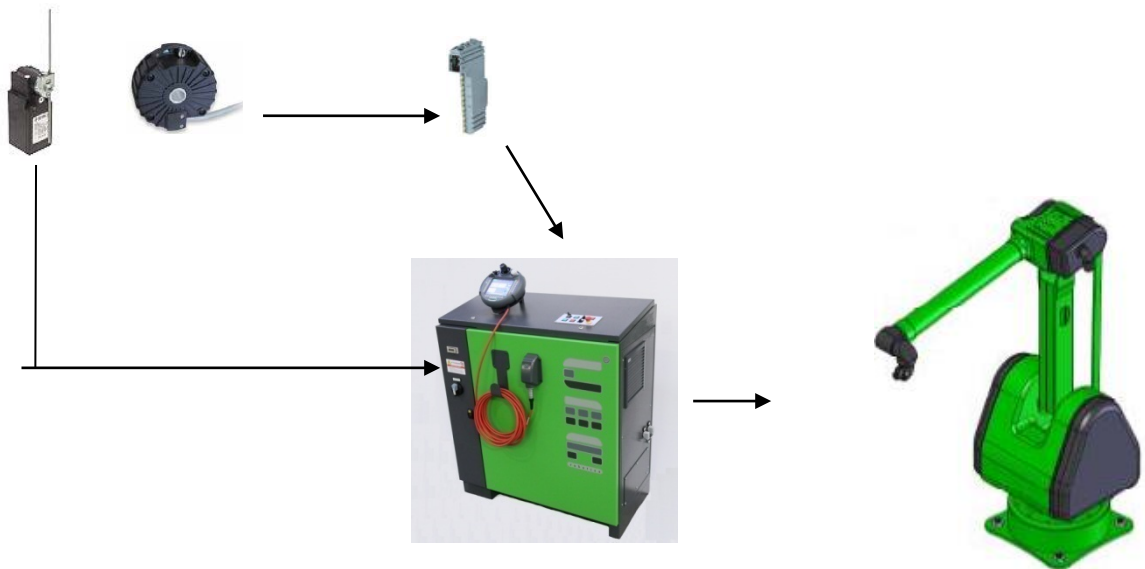

Incremental encoder 增量编码器	EH80P2048 Z5/L10X3PR331	Eltra
I/O module I/O 模块	X20DC1196 + TB12	B&R
Start limit switch 启动限位开关	FR550	Pizzato
Table17: Accessories for ST robot (SINCONV) 表 18: ST 型机器人配件 (SINCONV)		



Figure 30: SINCONV connection
SINCONV 的连接

- Switch off the electrical cabinet and open the door
- Locate the free slot n°9 on the I/O board assembly for inserting the X20DC1196 module
- 关闭电柜电源，打开电柜门
- 找到 I/O 板组的 9 号空闲插槽并插入 X20DC1196 模块



Figure31: SINCONV connection
SINCONV 的连接

- Insert the module
- 插入模块



Figure 32: SINCONV connection
SINCONV 的连接

- Get the TB12 connector and hold it with the little hook facing down.
- TB12 连接器保持朝下，挂住挂钩。

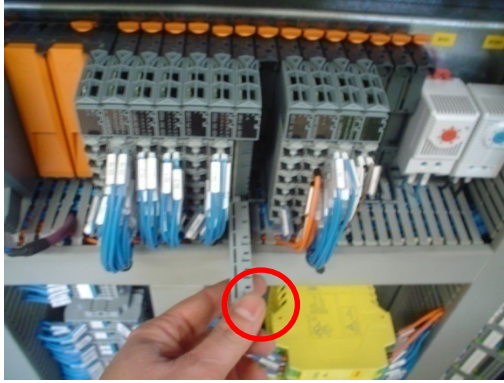

Figure 33: SINCONV connection
SINCONV 的连接

- Hook the TB12 connector onto the front of the module and rotate it up until the connector engages at the top.
- 钩住 TB12 连接到模块的前部，旋转直到所述连接器接合的顶部。



Figure 34: SINCONV connection
SINCONV 的连接

- Connector correctly slotted in
- 连接器正确插入槽中。



Figure 35: SINCONV connection
SINCONV 的连接

- Perform the wiring for the cable coming from the encoder as illustrated in greater detail in the diagram below
- 编码器电缆的接线下图中有更详细地说明

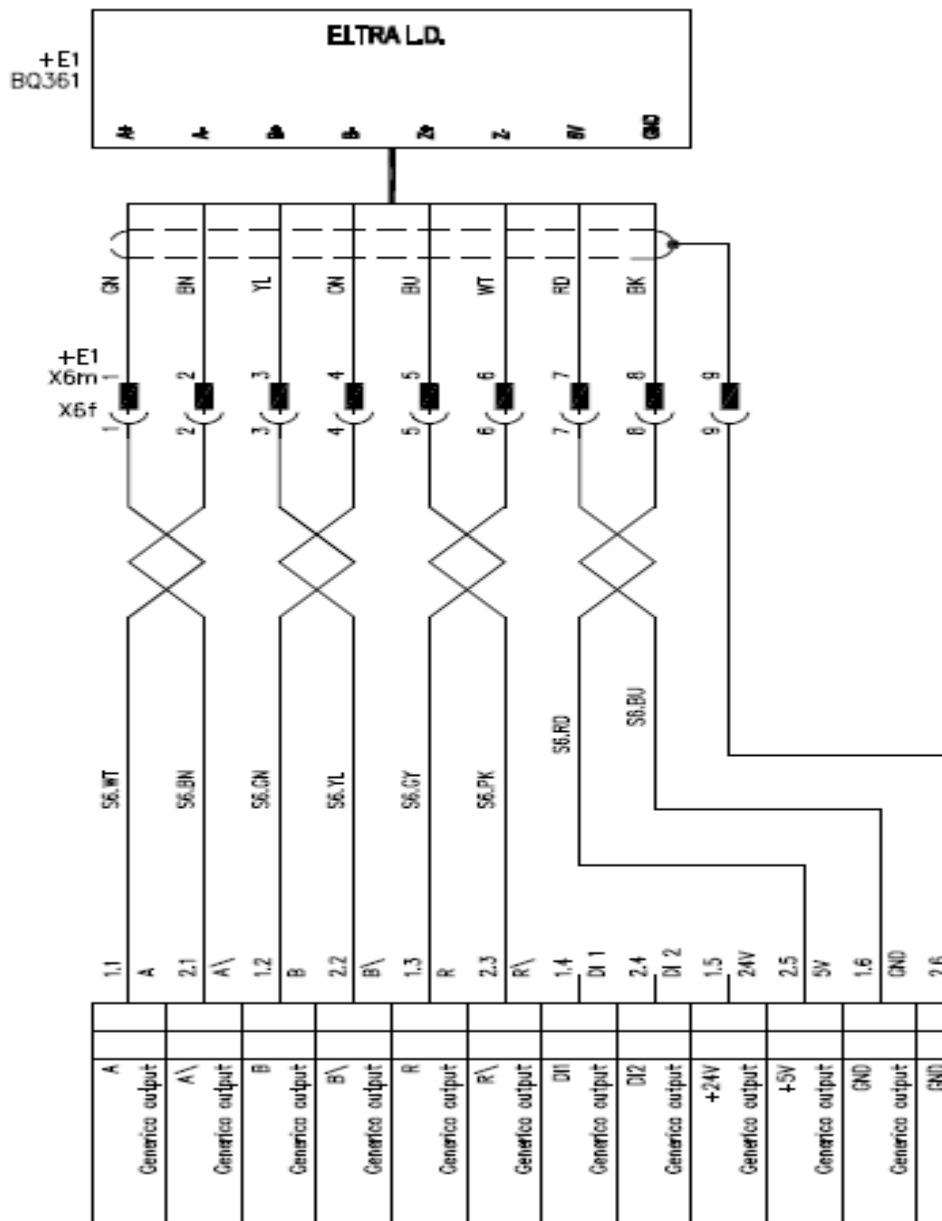

- Connect the start switch to terminals X2.8 and X2.10 see paragraph 06.3.8. Available input signals (X2)
- 连接启动开关至端子 X2.8 和 X2.10，参见第 1.3.8 可用的输入信号 (X2)

Figure36: SINCONV connection
SINCONV 的连接

1.3.11 Connecting the encoder for plant managing (APS version)喷涂编码器的连接（APS 版）

In the system with Robot automatic programming it is possible to keep count of the pieces scanned by the light curtains inside the system itself via an absolute *encoder* fitted on the conveyor's drive unit and connected to the I/O module to be inserted in the I/O board assembly. A limit switch activated by the first suspended tray conveyor shall reset the absolute encoder. 在机器人自动化编程的系统中，通过光幕记录被扫描件的块数，在输送机驱动装备的系统里，安装一个绝对值编码器，被连接的 I/O 模块安装到 I/O 的插槽中。由第一个悬挂输送机的托盘激活限位开关信号并复位绝对值编码器。

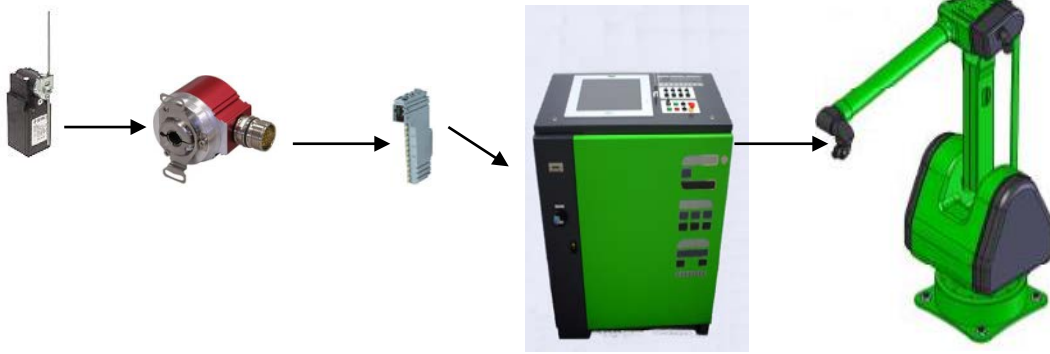

Absolute <i>encoder</i> 绝对值编码器	CS58M	T+R
I/O module I/O 模块	X20DC1198 + TB12	B&R
Reset limit switch 复位限位开关	FR550	Pizzato
Table18: Accessories for system management 表 19: 系统管理的附件		



Figure37: Connection of the system management *encoder*
系统管理编码器的连接

- Switch off the electrical cabinet and open the door
- Locate the free slot No. 10 on the I/O board assembly to insert module X20DC1198
- 关闭电柜电源，打开柜门
- 找到 I/O 板组的 10 号空闲插槽并插入 X20DC1198 模块

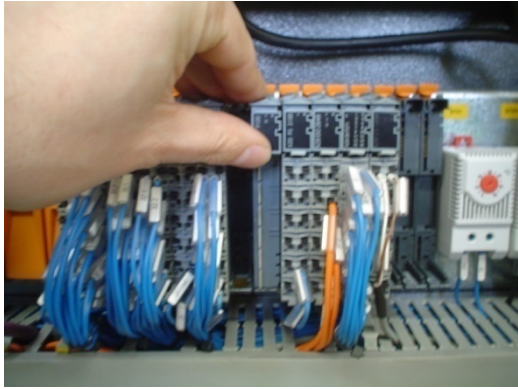

- Insert the module
- 插入模块

Figure38:Connection of the system management *encoder*
系统管理编码器的连接



- Get the TB12 connector and hold it with the little hook facing down.
- TB12 连接器保持朝下，挂住挂钩

Figure 39: Connection of the system management *encoder*
系统管理编码器的连接



- Hook the TB12 connector onto the front of the module and rotate it up until the connector engages at the top.
- 钩住 TB12 连接到模块的前部，旋转直到所述连接器接合的顶部。

Figure 30: Connection of the system management *encoder*
系统管理编码器的连接



Figure 40: Connection of the system management *encoder*
系统管理编码器的连接

- Connector correctly slotted in
- 连接器正确插入槽中。



Figure 41: Connection of the system management *encoder*
系统管理编码器的连接

- Perform the wiring for the cable coming from the encoder as illustrated in greater detail in the diagram below
- 编码器电缆的接线下图中有更详细地说明

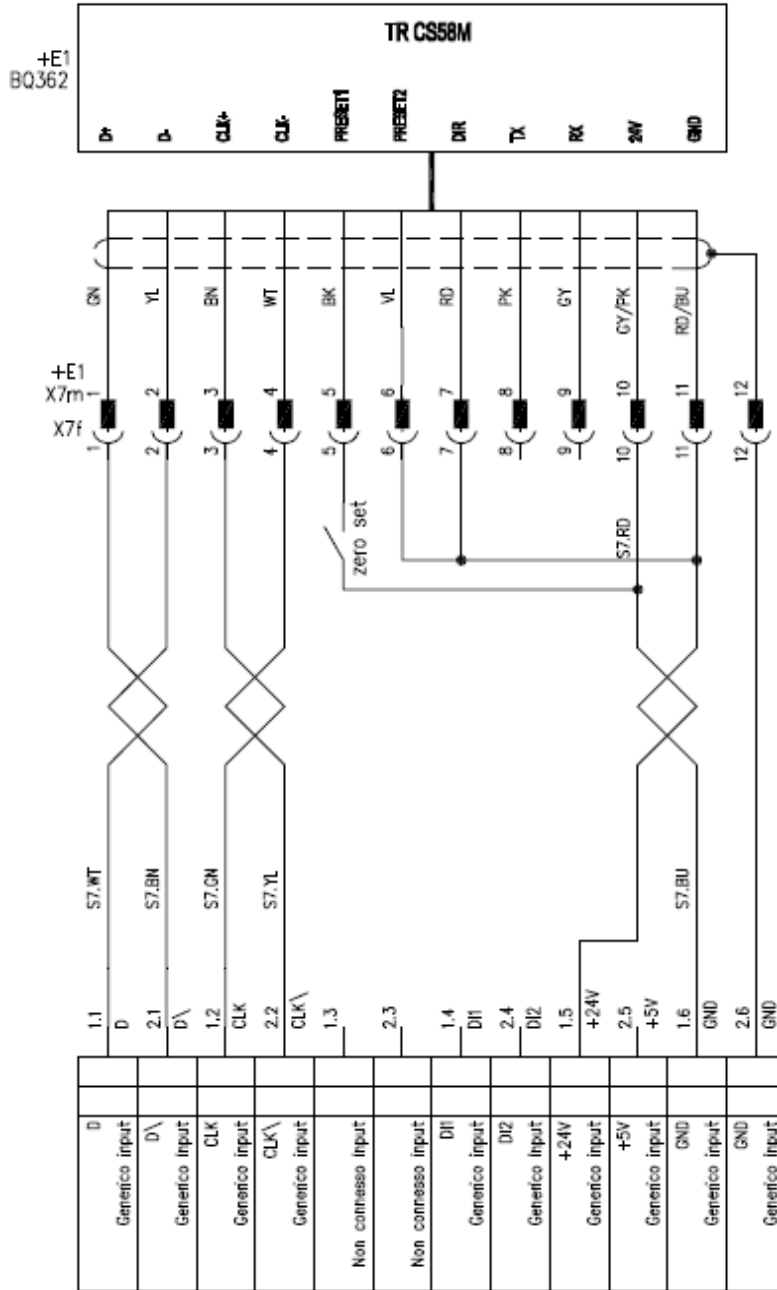

Figure22:Connection of the system management *encoder*
系统管理编码器的连接

- Connect cable S7 to module No. 9 X20DC1198 and the other end to connector X7f.
- Connect the encoder reset limit switch between pins 5 and 10 of connector X7f (red and black wires of the encoder)
- 连接 S7 至 9 号模块的 X20DC1198 以及另一端 X7f 端子。
- 连接编码器复位限位开关之间引脚 5 和 10 的连接器 X7f（红色和黑色的编码器导线）

1.3.12 Connecting the Measure Barriers (APS version 连接测量光栅(APS 版))

The (APS) Robot automatic programming system includes the use of measuring sensors suitable in height to the pieces to be scanned that are to be connected to the X9 terminal board of the electrical cabinet.

机器人(APS)自动编程系统包括使用合适的测量高度传感器进行扫描,并将其将连接到电柜的 X9 接线端子上。



Measuring sensors 测量传感器	CML730iT05xxxx + CML730iR05xxxx	Leuze
Table 19: Measuring sensor kit 表 20:测量传感器设备		

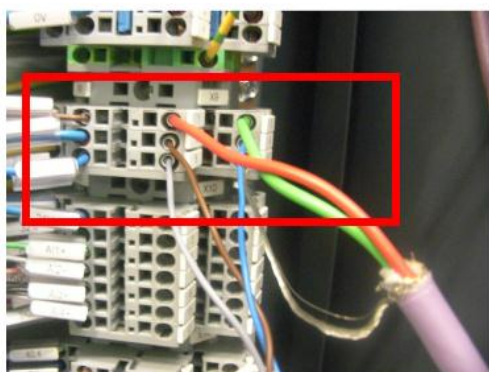

- Switch off the electrical cabinet and open the door
- Identify the X9 terminal board and connect cable S9 from Control unit four in compliance with the following diagram.
- 关闭电柜电源，打开柜门
- 确认 X 9 端子和按照下面的关联图连接第四单元控制的 S9 的线缆。

Figure43:Measuringsensor connection
测量传感器的连接

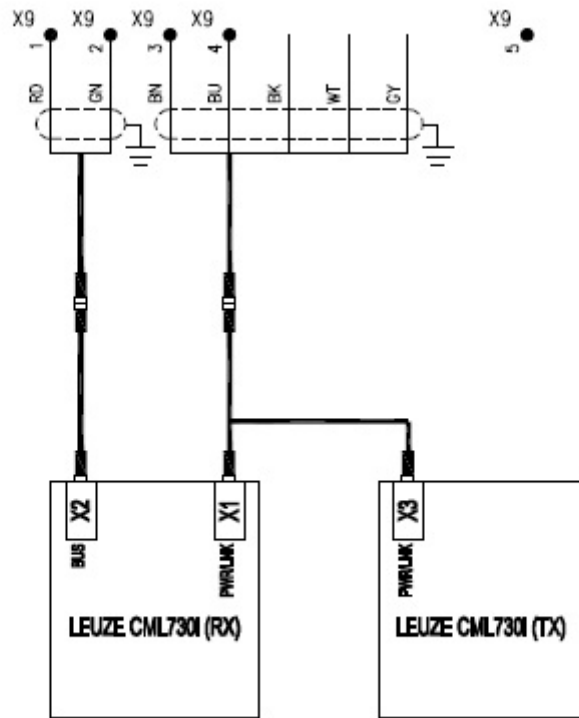
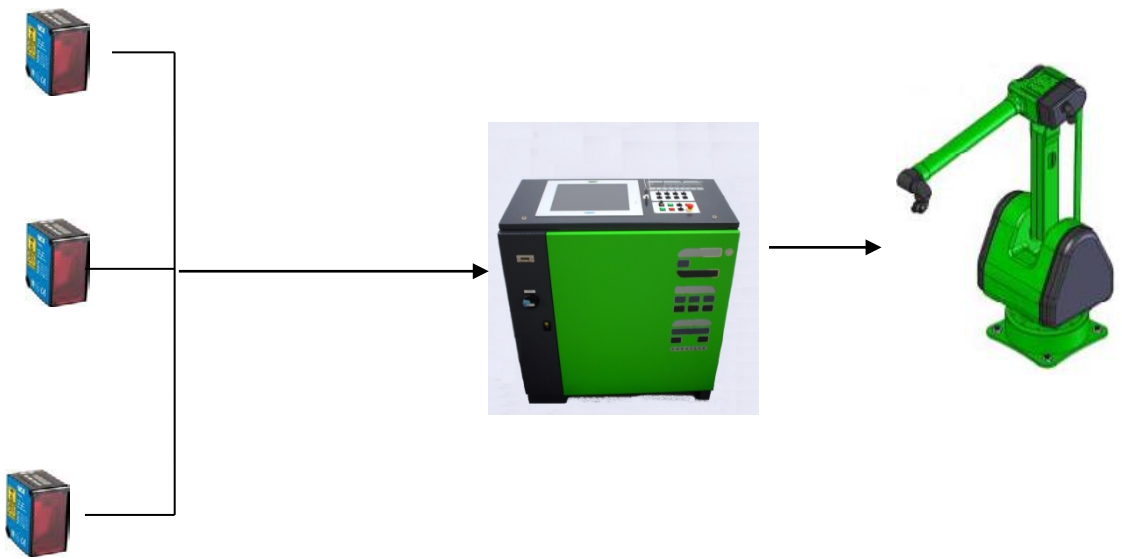

Figure44:Measuring sensor connection
测量传感器的连接

1.3.13 Connecting sensors for 3D option (option 3D)连接 3D 属性的传感器 (3D 选项)

Apart from the measuring sensors, three photocells measure the distance of the piece; they are located on the piece highest point, lowest point and average height point allowing to detect the piece tilt in relation to the perpendicular to that, during painting, the robot can get nearer or move away from the piece.

除了测量传感器，三个光电传感器可测量工件的距离;它们位于允许检测工件相对于垂直方向上倾斜的最高点、最低点和平均高度点，以方便在喷涂时机器人可以更加接近或远离工件。



Distance measuring photocells 距离测量传感器	DT50-P1113	Sick
Table20: 3D kit 表 21: 3D 扫描		

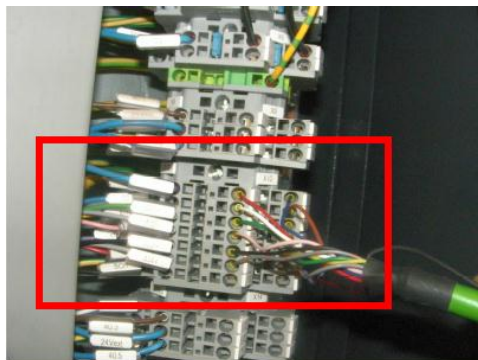

- Switch off the electrical cabinet and open the door
- Identify terminal board X10
- Connect cable S10 to terminal board X10, as explained in the diagram below.

- 关闭电柜电源，打开柜门□
- 确定接线端子板 X10
- 连接电缆 S10 向终端板 X 10，如下图中所述。

Figure45: 3D photocell connection
3D 光电传感器连接

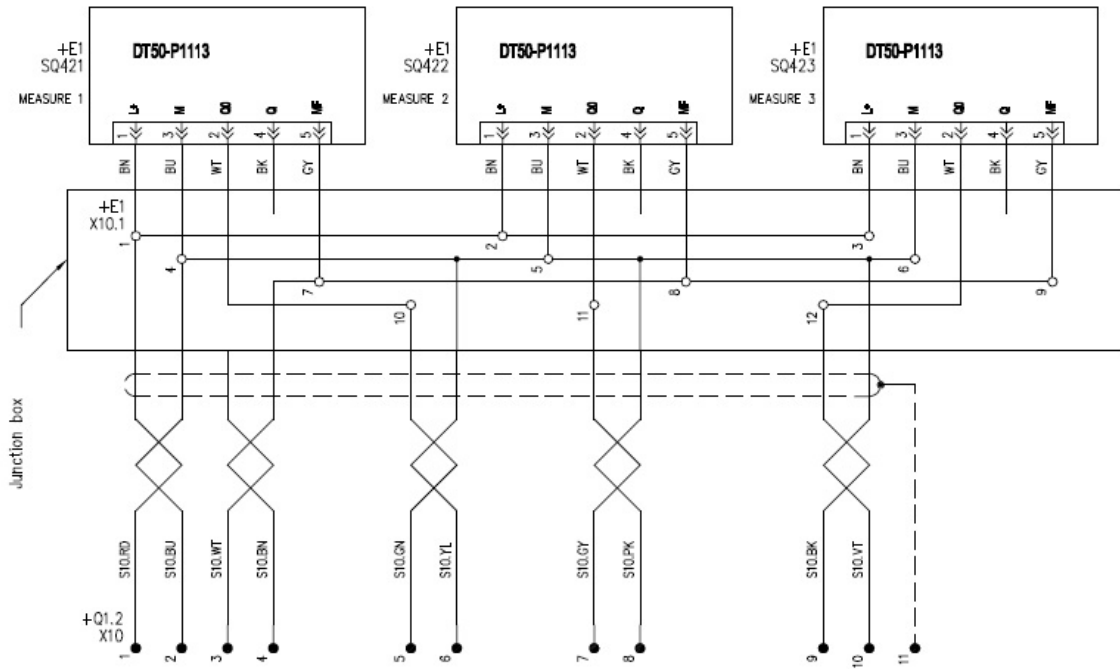

Figure46: 3D photocell connection
3D 光电传感器连接

1.3.14 Connecting the Start pedal for carousel loading (G models) 连接启动踏板至自带转盘型机器人 (G 型)

To enable carousel rotation after the part is loaded, you need to connect a pedal as specified in greater detail below.

若要启用装载后的旋转工作台，您需要按下面更详细地规定连接踏板。



Start pedal 启动踏板	PF18620025	Pizzato
Table21: Accessories for G robot G 型机器人配件		

- Switch off the electrical cabinet and open the door
- Connect the start pedal to terminals X2.8 and X2.9, see paragraph 06.3.8. Available input signals (X2)
- 关掉电柜电源和打开柜门
- 连接踏板开始到终端 X2.8 和 X2.9, 见 1.3.7 节可用输入信号 (X2)

1.3.15 Connecting Proportioning valves (CAPV accessory) 连接比例阀 (CAPV 附件)

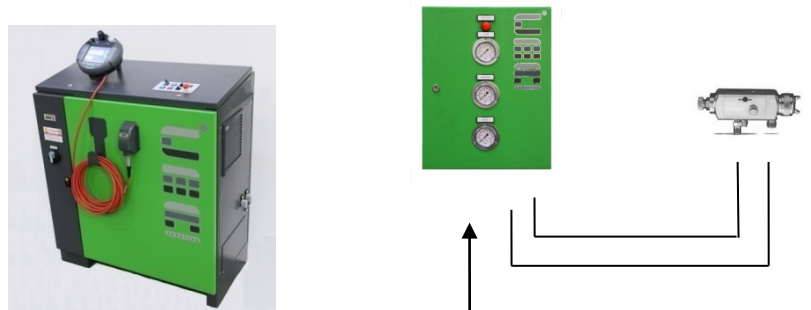

Proportioning valves 比例阀	CAPV B&R	Cma Robotics
X2X bus transmitter module X2X 总线模块	X20BT9100 + TB12	B&R
Stand 支持		Cma Robotics

Table22: CAPV accessory CAPV 附件

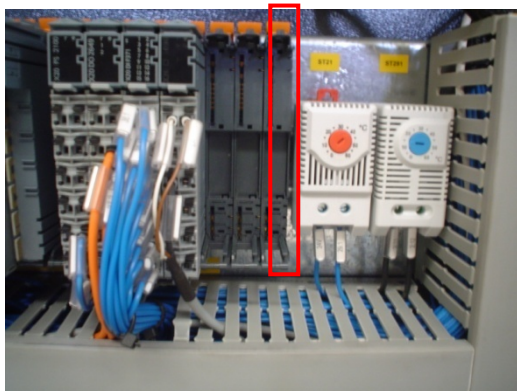

- Switch off the electrical cabinet and open the door
- Locate the free slot No. 17 on the I/O board assembly
- 关掉电柜电源和打开柜门。
- 在 I/O 组装板找到空闲插槽第 17 号。

Figure47: CAPV connection
CAPV 连接



- Insert the module in the slot
- 将模块插入到插槽中。

Figure48:CAPV connection
CAPV 连接



- Get the TB12 connector and hold it with the little hook facing down.
- TB12 连接器保持朝下，挂住挂钩。

Figure49:CAPV connection
CAPV 连接



- Connector correctly slotted in
 - 连接器正确插入槽中。
-

Figure 50:CAPV connection
CAPV 的连接

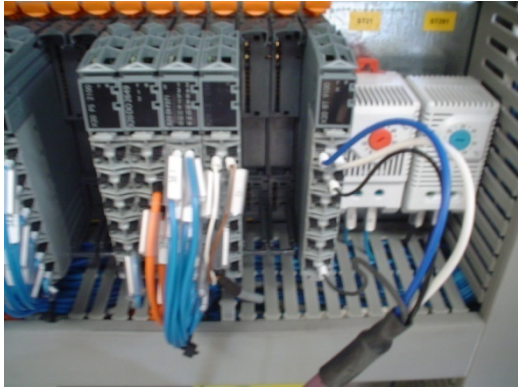

Figure 51:CAPV connection
CAPV 的连接

- Perform the wiring for the violet cable coming from the proportioning valve box as illustrated in greater detail in the diagram below
- 如下图中更详细地说明比例阀箱中紫色电缆的布线。

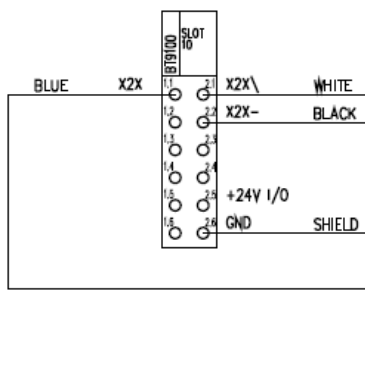

Figure 52:CAPV connection
CAPV 的连接

- Wiring diagram
- 接线图



Figure233:CAPV connection
CAPV 连接

- Connect the box's power cable to terminal block X6 (24Va = 24V 4A)
- 连接盒子的电源线接线端子 X6(24Va = 24V 4A)

1.3.16 Ethernet connection (standard)以太网连接（标准）

The Robot's cabinet can be connected to the company network in order to take advantage of the CMA remote assistance or to automate the sending of programs to the Robot. Connection can be made using the Ethernet jack on the cabinet's right side or by connecting a network cable to the switch located inside the cabinet.

机器人的电柜可连接到公司网络，以便利用 CMA 远程协助的功能或自动发送程序至机器人。连接可以通过在机柜的右侧以太网插孔进行或通过安装在电柜内部交换机连接网络。

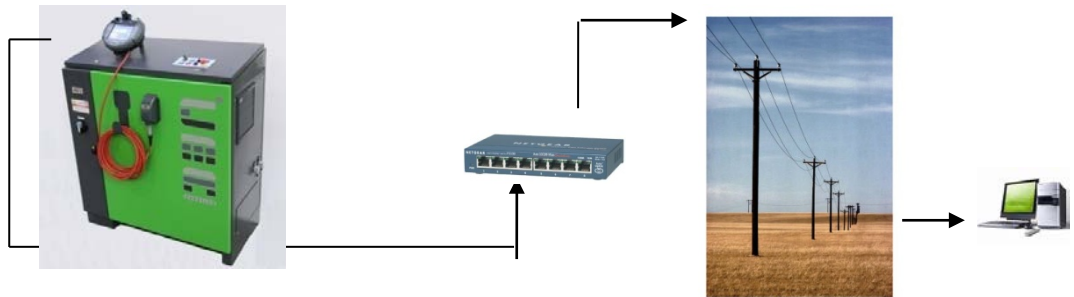

- Locate the *Ethernet* port on the left hand side of the electrical cabinet between the two available ports (USB + *Ethernet*)
- Unscrew the protective cap and connect the network cable
- 在电柜左手边两个可用端口之间，可以找到以太网口(USB+以太网)
- 旋开保护帽和连接网络电缆

Figure 54: Ethernet connection
以太网连接

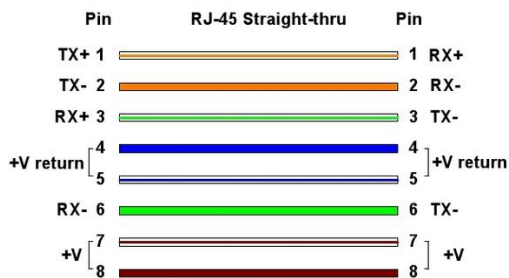

- Refer to the cable diagram on the left and use shielded cat 5 Ethernet cables
- 参见左侧的电缆图并使用屏蔽 5 类以太网电缆



Figure24: Ethernet connection
以太网连接

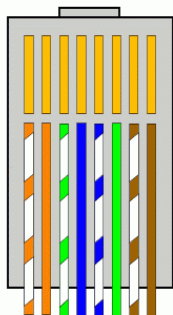
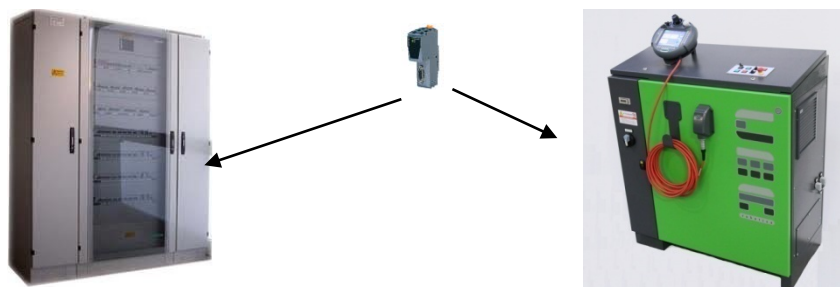

Figure56: Ethernet connection
以太网连接

1.3.17 Connecting the Profibus module (PROFI accessory) 连接 Profibus 总线模块 (PROFI 附件)

The Robot's electrical cabinet can be interfaced using the "Profibus" field bus. The Robot can be inserted in a Profibus network as a Slave, which means there must be a unit in the network acting as the Master. You will need to let CMA know the node the Robot belongs to in the Profibus network the cabinet will be inserted in before the machine is dispatched. CMA will arrange to have it inserted

该机器人的电柜可以采用 Profibus 现场总线接口。机器人可以被插入在一个 Profibus 网络作为一个从站，这意味着必须有一个单元充当网络中的主站。在机器人发货前，您需要让 CMA 知道机器人从属 Profibus 网络中的节点。CMA 会安排将其插入。



Slave Profibus module Profibus 从站模块	X20IF1063-1	B&R
Profibus connector Profibus 连接器	0G1000.00-90	B&R
Table23: Accessories for robot 表 27: 机器人配件		

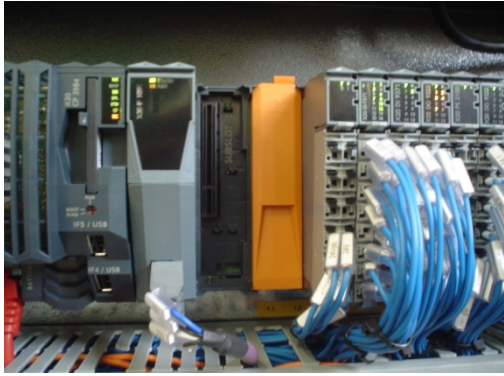

Figure57:Profibus module connection
Profibus 模块连接

- Switch off the cabinet and open the door
- Locate the first free slot on the left of the I/O board assembly
- Remove the orange cap
- 电柜断电，打开柜门
- 在 I/O 板总成的左边找到第一个空闲插槽
- 取下橙色盖帽



Figure58:Profibus module connection
Profibus 模块连接

- Insert the X20IF1063-1 module
- 插入 X20IF1063-1 模块



Figure59:Profibus module connection
Profibus 模块连接

- Connector for Profibus module
- Profibus 总线模块的连接器

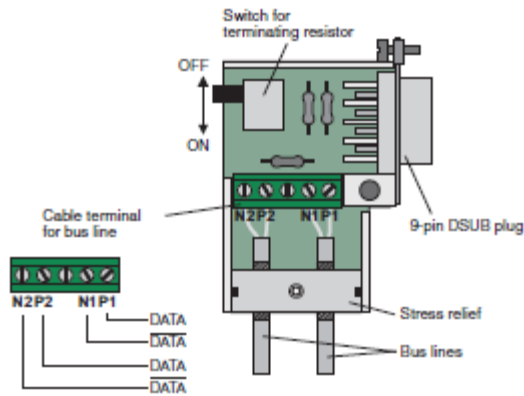

Figure60 :Profibus module connection
Profibus 模块连接

- Perform the wiring on the DB9 connector as specified in the figure on the left.
- With more electrical cabinets on the same network, position the termination switch in the last cabinet to ON.
- 按照左图标识对 DB9 接头连接进行布线
- 随着在同一网络上更多的电柜，将最后的电柜上的终端开关拨至 ON。

1.4 Available communication interfaces 可用的通信接口

1.4.1 .Ethernet communication (standard)以太网通信（标准）

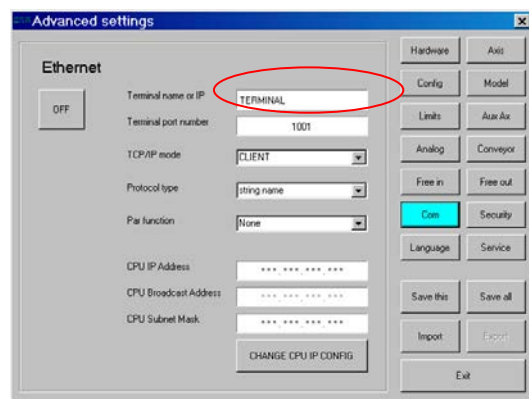

Figure 61: Ethernet communication
以太网通讯

The Robot can be connected to a TCP/IP Server using the classic Client-Server configuration. The Robot and Client attempt to connect to the Server while they are booting up. 机器人可以使用经典的客户端 - 服务器配置去连接到 TCP / IP 服务器。启动时，机器人和客户端试图连接到服务器。

- By entering the **AdvancedSettings** menu and pressing the **Com** button, you can set the name of the Server the Robot is to connect to. 通过进入 **AdvancedSettings** 菜单,并按 **Com** 按钮,您可以设置需要机器人连接的服务器的名称。

There are two kinds of protocol:
这里有两种协议:

- string name
- 字符串命名
- CMA standard
- CMA 标准

Byte	char	Description
1	T	First character 第一个字符
2	a	
3	b	
4	l	
5	e	Last character 最后一个字符
7	CR	Return character 返回字符
8	LF	Line feed character 换行符

Table 24: "String name" command string structure
表 28: “字符串名称”的字符串命令结构

The "string name" protocol is simple, all you need to do is send the Robot a string with the name of the program to be executed and, if the program is stored in the Robot's program files, the program will be added to the work list. The string must end with the return and line feed characters.

字符串命名的协议很简单，你所要做的就是将执行程序名以字符串的形式发送给机器人。如果程序存储在机器人的程序文件中，则程序会被添加到工作列表中。字符串必须以返回字符和换行字符结束。

Byte 字节	Char 字符	Description 描述
1	<	Command string start character 命令字符串起始字符
2		Command 命令
3	&	Separator 分隔符
4		Parameter 1 参数 1
5		
6		
n		
n+1	&	Separator 分隔符
n+2		Parameter 2 参数 2
	&	Separator 分隔符
		Parameter n 参数 n
	>	Command string end character 命令字符串结束字符

Table 25: "CMA standard" command string structure
表 29: CMA 标准的字符串命令结构

The "CMA standard" protocol command string varies in length and has the structure illustrated in the table on the left

“CMA 标准”协议的命令字符串的长度变化和结构说明在左边的表中说明。

1.4.1.1 List of Ethernet command.以太网命令列表

Below is a list of possible commands:

下面是一个可能的命令列表:

		Description 描述
Command 命令	1	Adds a program to the end of the work list 增加了一个程序到工作列表的末尾
Parameter 1 参数 1	Program path	Path of the program 程序的路径
Parameter 2 *参数 2	number	colour assigned to program * = optional 颜色分配给程序* =可选
Examples 样例	<1&Table>	Add the Table program 添加表程序
	<1&Table&3>	Add the Table program using colour n°3 使用颜色 n° 3 添加表程序
Table26: Add program command 表 30: 添加程序命令		

		Description 描述
Command 命令	4	Deletes from work list (only if Robot is not in Automatic mode) 从工作列表中删除（仅在机器人不在自动模式下）
Examples 样例	<4>	
Table27: Work list delete command 表 31:工作列表中删除命令		

		Description 描述
Command 命令	5	Minimizes CMAnet software window 最小化 CMAnet 软件窗口
Examples 样例	<5>	
Table28: Insert program command 表 32: 插入程序指令		
		Description 描述
Command 命令	100	Carousel Rotation command 旋转台旋转命令

Examples 样例	<100>	
Table29: Insert program command 表 33: 插入程序指令		

1.4.1.2 List of replies to Ethernet commands 以太网指令应答列表

Below is a table summarizing replies to Ethernet commands

下面的表格概括了应答以太网命令

Generic replies 通用的应答	Description 描述
<0>	Command executed 执行命令
<1>	Syntax error 语法错误
<2>	No such command 没有这样的命令
<3>	Command not permitted 命令不允许
<4>	Incorrect number of parameters 不正确的参数数目
Replies to work list edit commands 回复工作列表编辑命令	
<10>	No such program 没有这样的程序
<11>	Syntax error 语法错误
<12>	Work list locked 锁定工作列表
<13>	Invalid parameter 无效的参数
Robot status replies 机器人状态回复	
<20>	Robot in alarm condition 机器人在报警状态
<21>	Motors are off (e.g. in reply to command 5) 电机关闭（例如，在回答命令 5 时）
<22>	Carousel not ready 旋转件未准备好
<23>	Carousel moving 旋转件移动
<100>	Generic error 通用的错误
Table30: Reply codes in response to commands 表 34 应答指令代码	

1.4.2 Communication Profibus (accessory PROFI) Profibus 总线通讯 (PROFI 配件)

The Profibus protocol can be used to split a memory area into 64 bits for reading and 64 bits for writing. In the writing memory area, you can add programs to the Robot's execution list and send start commands; in the reading area, you can read the state of certain signals, such as those described in 06.3.9. Available **output signals (X3)**, and specified in greater detail in the tables below. Profibus 协议可用于分割存储区域并划分成 64 位用于读和 64 位进行写入。在写入的内存区域，您可以添加程序到机器人的执行列表和发送开始命令；在读取内存区，可以读取的某些信号的状态，如那些在 1.3.9 节介绍的输出信号（X 3）中所描述的状态。下表时更具体的描述：

Bit 位	Meaning 含义	
1-32	<i>Command string</i> 命令字符串	Command string, see table of commands 字符串命令，见表命令
33	<i>Command string confirmation</i> 命令字符串确认	Confirmation of command string, if you set the value 1, the command present in bits 1-32 is processed. 命令字符串的确认，如果设置为 1，该命令出现在 1-32 位处理。
34	<i>Remote start in stand-by</i> 远程启动备用	When this bit changes from 0 to 1, the Robot – which had previously reached the first point of the program – starts the work cycle. 当该位从 0 变化为 1 时，机器人 - 而先前达成的程序的第一个点 - 开始工作循环。
35	<i>Remote start in positioning</i> 远程启动定位	When this bit changes from 0 to 1, the Robot reaches the first point of the program and then starts executing the work cycle. 当该位从 0 改变为 1，则机器人到达程序的第一点，然后开始执行工作循环。
36	<i>Continuous start</i> 连续开始	The Robot will continue to execute the program without stopping for as long as the value of this bit stays at 1. 该机器人将继续不停止，只要该位的值保持在 1 至执行程序。
37-64	<i>Free</i>	

Table31: Allocation of Profibus communication writing memory bits
Profibus 连接线字节

Bit	Meaning	
1	<i>Answer ready 应答就绪</i>	Control bit to communicate that the reply to a command is ready, the bit switches from 0 to 1 and returns to 0 after 200 ms 控制位的通信的回复的命令是准备就绪, 该位开关从 0 变到 1, 并在 200 毫秒后返回到 0 后
2	<i>Command string answer 命令字符串应答</i>	Reply to commands sent, see table of replies 回复发送的命令, 见应答表
3	<i>Robot busy 机器人忙</i>	If the value is 1, it indicates that the robot's work list contains at least one program (corresponds to digital signal on X2.3) 如果值为 1, 则表明, 机器人的工作列表包含至少一个程序(X2.3 对应于数字信号)
4	<i>Program running 程序运行</i>	
5	<i>Component running 组件运行</i>	
6	<i>Robot in stand by 机器人待机</i>	If the value is 1, it indicates that the robot has reached the first point of the program and is standing by for a remote start. (corresponds to digital signal on X2.1) 如果该值为 1, 则表示该机器人已达到程序的第一点和远程启动处于待机状态。(对应于 X2.1 数字信号)
7	<i>Empty list 空列表</i>	If the value is 1, it indicates that the Robot's work list is empty 如果值为 1, 则表明, 机器人的工作列表是空的
8	<i>Washing position 1 清洗位置 1</i>	If the value is 1, the Robot has reached washing position n° 1 如果该值为 1, 机器人已经达到清洗位置 n° 1
9	<i>Washing cycle 1 清洗周期 1</i>	If the value is 1, washing cycle n° 1 is in progress 如果该值为 1, 清洗周期 n° 1 正在进行
10	<i>Washing position 2 清洗位置 2</i>	If the value is 1, the Robot has reached washing position n° 2 如果该值为 1, 则机器人已经达到清洗位置 n° 2
11	<i>Washing cycle 2 清洗周期 2</i>	If the value is 1, washing cycle n° 2 is in progress 如果该值为 1, 清洗周期 n° 2 正在进行中
12	<i>Washing position 3 清洗位置 3</i>	If the value is 1, the Robot has reached washing position n° 3 如果该值为 1, 则机器人已经达到清洗位置 n° 3
13	<i>Washing cycle 3 清洗周期 3</i>	If the value is 1, washing cycle n° 3 is in progress 如果该值为 1, 清洗周期 n° 3 正在进行
14	<i>Washing position 4 清洗位置 4</i>	If the value is 1, the Robot has reached washing position n° 4 如果该值为 1, 则机器人已经达到清洗位置 n° 4
15	<i>Washing cycle 4 清洗周期 4</i>	If the value is 1, washing cycle n° 4 is in progress 如果该值为 1, 清洗周期 n° 4 正在进行

16	<i>Robot in error</i> 机器人处于错误状态	If the value is 1, the Robot is in an error condition 如果该值为 1，则机器人处于错误状态
17	<i>Robot in emergency</i> 机器人在紧急状态	If the value is 1, the Robot is in emergency mode 如果该值为 1，则机器人处于紧急状态
18-19	<i>Analog output 1</i> 模拟量输出 1	From 0 to 1000 value of analogue output 1 (bit low, bit high) 从 0 到 1000 的值模拟输出 1(低位,高位)
20-21	<i>Analog output 2</i> 模拟量输出 2	From 0 to 1000 value of analogue output 1 (bit low, bit high) 从 0 到 1000 的值模拟输出 1(低位, 高位)
22-23	<i>Analog output 3</i> 模拟量输出 3	From 0 to 1000 value of analogue output 1 (bit low, bit high) 从 0 到 1000 的值模拟输出 1(低位, 高位)
24-25	<i>Analog output 4</i> 模拟量输出 4	From 0 to 1000 value of analogue output 1 (bit low, bit high) 从 0 到 1000 的值模拟输出 1(低位, 高位)
26-27	<i>Analog output 5</i> 模拟量输出 5	From 0 to 1000 value of analogue output 1 (bit low, bit high) 从 0 到 1000 的值模拟输出 1(低位, 高位)
28-29	<i>Analog output 6</i> 模拟量输出 6	From 0 to 1000 value of analogue output 1 (bit low, bit high) 从 0 到 1000 的值模拟输出 1(低位, 高位)
30-31	<i>Analog output 7</i> 模拟量输出 7	From 0 to 1000 value of analogue output 1 (bit low, bit high) 从 0 到 1000 的值模拟输出 1(低位, 高位)
32-33	<i>Analog output 8</i> 模拟量输出 8	From 0 to 1000 value of analogue output 1 (bit low, bit high) 从 0 到 1000 的值模拟输出 1(低位, 高位)
34-64	<i>Free</i> 空闲	
Table32: Allocation of Profibus communication reading memory bits 表 36:现场总线 Profibus 通信读取内存分配		

Profibus communication flow diagram

Profibus 通讯流程图

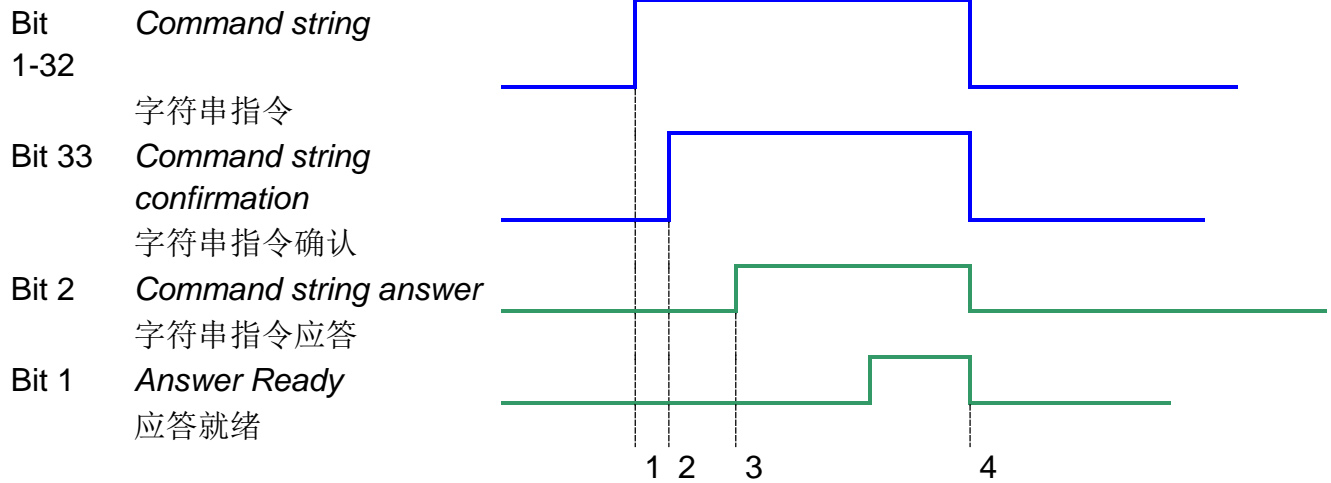

- 1) Write the command string in bits 1-32 在 1-32 位写入命令字符串
- 2) Write 1 in confirmation bit 在校验位写入 1
- 3) The Robot prepares the reply 机器人准备应答
- 4) The Robot writes 1 in reply bit 1 and deletes it after 200 ms. 机器人写 1 回答 1 位，200 毫秒后删除。

For details on command strings and reply codes, see sections List of Ethernet commands and List of replies to Ethernet commands above.







有关命令字符串和应答代码的详细信息，请参阅以上部分清单的以太网命令和以太网应答命令列表。

1.5 AXIS ERROR MESSAGES 关节轴错误信息

The following Table features the most significant error messages concerning the motors' drives. 下面的表提供关于电机驱动器中最重要的错误消息。

6019		<i>ACOPOS: Overcurrent</i> 驱动器: 过流	The drive has detected a current demand higher than the motor's maximum rating 驱动器检测到超过电机的最大额定电流	Possible causes: 可能的原因: <ul style="list-style-type: none"> • Incorrect motor wiring • 不正确的电机连接 • Short-circuit between phase and earth wire 相线和接地线之间的短路 • Short-circuit between two of motor's phases 两个电机相位之间的短路 • Drive defective • 驱动器有缺陷
6020		<i>Hardware: 24V power supply fail</i>	24V DC supply has dropped below minimum	PWa auxiliary power supply defective

	.	硬件: 24V 电源故障	level 24V 直流电降至最低水平	PWa 辅助电源供电故障
6021	A	Low level at controller enable input 控制器使能端输入低电平	The drive's Enable input has dropped below minimum level while drive is running 驱动器运行时, 驱动器的使能输入降至最低水平	<ul style="list-style-type: none"> • Switch cabinet off and back on • 电柜断电然后重新上电 • Check operation of safety PLC's O0 output • 检查安全 PLC 的 O0 输出的操作 • Replace the safety PLC • 更换安全 PLC
6028	A	Holding brake: Undervoltage/ - current 抱闸: 欠压/- 电流	With motor holding brake released, no current comes through 随着电机抱闸释放, 没有电流通过	<ul style="list-style-type: none"> • Check motor brake wiring • 检查电机抱闸线
6029	A	Holding brake: Control signal on and output status off 抱着制动: 控制信号打开和输出状态关闭	When motor's holding brake is released, no current comes through after 500ms 当电机的抱闸被释放, 500 毫秒后没有电流通过	<ul style="list-style-type: none"> • Check motor brake wiring • 检查电机抱闸线
6045	A	Power stage: Connection X5: No current flow #: phase 功率等级: 连接 X5: 无电流 #: 相	When motors are switched on, no current comes through 当电动机上电后, 没有电流通过	<ul style="list-style-type: none"> • Incorrect motor wiring • 电机接线不正确 • Check the resistance between motor phases: it must be finite and the same for all three phases. • 检查电机各相之间的电阻: 它必须在所有三相相同
7017	A	Encoder: Error while reading encoder parameter #: slot 编码器: 读取时出现错误参数 #: 插槽	Error from conveyor speed I/O module 输送机速度 I/O 模块的错误	Check the connecting cable 检查连接电缆
7022	A	Initialization is active 初始化激活	Motor feedback encoder initialization has not been completed 电机反馈编码器初始化尚未完成	<ul style="list-style-type: none"> • Check Rn or Dn connecting cable for damage • 检查 Rn 或 Dn 连接电缆的受损情况 • Motor feedback encoder

				<ul style="list-style-type: none"> is defective 电机反馈编码器有缺陷
7029		<p><i>Incremental signal amplitude too small</i> 增量信号幅度太小</p>	<p>Encoder signal amplitude is 20% less than prescribed maximum 编码器信号的幅度比规定的最高限额低 20%</p>	<ul style="list-style-type: none"> Check Rn or Dn connecting cable for damage 检查 Rn 或 Dn 连接电缆的受损情况 Motor feedback encoder is defective 电机反馈编码器有缺陷
7032		<p><i>Encoder: Incremental signal amplitude too small (Disturbance, no connection)</i> 编码器: 增量信号幅度过小 (受干扰, 没有连接)</p>	<p>Encoder signal amplitude is 10% less than prescribed maximum 编码器信号的幅度比规定的最高限额低 10%</p>	<ul style="list-style-type: none"> Check Rn or Dn connecting cable for damage 检查 Rn 或 Dn 连接电缆的受损情况 Motor feedback encoder is defective 电机反馈编码器有缺陷
7046		<p><i>Resolver: cable disturbance</i> 解析器: 电缆干扰</p>	<p>The motor feedback resolver returns signals with amplitude that is too low 电机反馈解析器返回振幅信号过低</p>	<ul style="list-style-type: none"> Make sure the Rn cable is connecte 确保 Rn 的电缆连接
7200		<p><i>DC bus: Overvoltage 直流母线: 过压</i></p>	<p>The DC bus voltage supplying the drives has exceeded the maximum limit 供应驱动器直流总线电压已超过最大限制</p>	<ul style="list-style-type: none"> A movement has been performed with acceleration or deceleration too high 运动的加速或减速过快 La resistenza di frenatura non funziona 制动电阻器不工作
7210		<p><i>DC bus: Voltage unstable 直流总线: 电压不稳</i></p>	<p>The DC bus voltage supplying the drives has exceeded the maximum limit 供应驱动器直流总线电压已超过最大限制</p>	<ul style="list-style-type: none"> Check that supply voltage is within required range 检查电源电压是否在要求的范围内 Check that all three phases are present 检查所有三相电压
7211		<p><i>DC bus: Voltage drop -check the power line 直流总线: 电压降—检查电源线</i></p>	<p>There has been a voltage drop on the DC bus supplying the drives 供应驱动器的直流总线电压降低</p>	<ul style="list-style-type: none"> Check that supply voltage is within required range 检查电源电压是否在要求的范围内 Check that all three

				<p>phases are present</p> <ul style="list-style-type: none"> • 检查所有三相电压
7215	<p>A</p> <ul style="list-style-type: none"> • 	<p><i>DC bus: At least one phase of the power line failed</i> 直流总线: 至少一相电压出现故障</p>	<p>One phase of main power supply missing 主电源单相电压丢失</p>	<ul style="list-style-type: none"> • Check that all three power supply phases are present • 检查当前的三个电源电压 • Check the FU110 and FU111 fuses • 检查 FU110 和 FU111 保险丝
7225	<p>A</p> <ul style="list-style-type: none"> • 	<p><i>DC bus: Overvoltage</i> 直流总线: 过压</p>	<p>Same as 7200 同 7200</p>	

Table33: Axis errors (code 01) 1/2 表 37: 轴的错误信息（代码 01）1/2

9000	<p>A</p> <ul style="list-style-type: none"> • 	<p><i>Heatsink temperature sensor: Overtemperature – Movement stopped</i> 散热器温度传感器: 过热 - 运动停止</p>	<p>The temperature sensor on the heat sink has detected a temperature higher than the limit 在散热片上的温度传感器检测到高于极限温度</p>	<p>Ambient temperature is higher than 40°C 环境温度高于 40° C</p> <ul style="list-style-type: none"> • Make sure that the electrical cabinet's cooling device (forced ventilation or air conditioner) is working properly • 确保电气柜的冷却装置（强制通风或空调）工作正常 • Make sure that the drives' cooling fans are working properly • 确保驱动器的冷却风扇正常工作
9001	<p>A</p> <ul style="list-style-type: none"> • 	<p><i>Heatsink temperature sensor: Overtemperature – Limiter active</i> 散热器温度传感器: 过热 - 限制器活跃</p>	<p>An increase has been detected in the heat sink temperature during a stopping movement. 在停止运动时，检测到散热器温度一只上升。</p>	<p>A movement has been performed with acceleration or deceleration too high 当前运动加速或减速过快。</p>
9002		<p><i>Heatsink temperature</i></p>	<p>The temperature detected</p>	<p>If ambient temperature is</p>

	A	<p><i>sensor: Not connected or destroyed</i> 散热器温度传感器: 未连接或毁坏</p>	<p>on the drive's heat sink is below -20°C 驱动器的散热器上温度检测低于-20° C</p>	<p>not below -20°C, then the drive is defective 如果环境温度不低于-20°C, 则该驱动器是有缺陷</p>
9003	A	<p><i>Heatsink temperature sensor: Not connected or destroyed</i> 散热器温度传感器: 未连接或毁坏</p>	<p>The temperature detected on the drive's heat sink is higher than 120°C 温度检测到驱动器的散热器是高于 120° C</p>	<p>Make sure that the drives' cooling fans are working properly 确保驱动器的冷却风扇是否工作正常</p>
9010	A	<p><i>Temperature sensor (Motor / Choke / External): Overtemperature</i> 温度传感器 (电机 电抗器 外部): 过热</p>	<p>A temperature has been detected beyond the limit for the motor being monitored 所监测电动机温度已超过临界范围</p>	<ul style="list-style-type: none"> • Check ambient temperature • 检查环境温度 • Motor temperature sensor connected on X4 is defective • 连接在 X4 上的电机温度传感器是有缺陷
9030	A	<p><i>Junction temperature model: Overtemperature – Movement stopped</i> 结温模式: 过热 - 运动停止</p>	<p>The mathematical model that calculates the theoretical temperature reached by the motor has produced a value beyond the maximum limit 由数学模型计算的电机所能达到的理论温度值超出最大极限值</p>	<ul style="list-style-type: none"> • Load too high • 负载过高 • A movement has been performed with acceleration or deceleration too high • 当前运动加速或减速过快。
9040	A	<p><i>Bleeder temperature model: Overtemperature – Movement stopped</i> 泄放温度模型: 过热 - 运动停止</p>	<p>The mathematical model that calculates the theoretical temperature reached by the braking resistor has produced a value beyond the maximum limit 由数学模型计算的制动带电阻所能达到的理论温度值超出最大极限值</p>	<ul style="list-style-type: none"> • A movement has been performed with acceleration or deceleration too high • 当前运动加速或减速过快。
9075	A	<p><i>ACOPOS continuos power: Overload – Movement stopped</i> ACOPOS 连持功率: 超载 - 运动停止</p>	<p>DC power has exceeded maximum limit 直流电源已超过最大限度</p>	<ul style="list-style-type: none"> • A movement has been performed with acceleration or deceleration too high • 当前运动加速或减速过快。
32189		<p><i>Timeout for cyclic data</i></p>	<p>Communication error on</p>	<ul style="list-style-type: none"> • Check the connections

	A	<i>from drive – Indications invalid (network error # timeout #) 驱动器的超时时间循环数据,显示无效 (网络错误#超时#)</i>	Powerlink network between drives and PLC 驱动器和 PLC 之间的 Powerlink 上网络通信错误	(red network cables) • 检查连接网络电缆(红色)
39003	A	<i>EnDat encoder: Alarm bit is set # : slot EnDat 编码: 报警位被设置 #: 插槽</i>		
39005	A	<i>EnDat encoder: Alarm bit – Signal amplitude too small # : slot EnDat 编码: 报警位 - 信号幅度太小 #: 槽</i>	The motor feedback encoder returns signals with amplitude that is too low 电机反馈的编码器返回的信号与振幅太低	The encoder is defective 编码器是有缺陷
39017	A	<i>Encoder: CRC error while reading position 编码器: 读取位置时的 CRC 错误</i>	Checksum error detected while reading the encoder position 读取编码器位置时检测到校验错误,	Interference present 存在干扰
41001	A	<i>Heatsink temperature sensor: Overtemperature # : Heatsink temperature 散热器温度传感器: 过热 #: 散热器温度</i>	The temperature sensor on the heat sink has detected a temperature higher than the 0.95*103°C limit 在散热片上的温度传感器检测的温度高于 0.95 * 103°C	See error number 9000 参考错误编号 9000
41011	A	<i>Temperature sensor (Motor Choke External): Overtemperature 温度传感器 (电机 电抗器 外部): 过热</i>	A temperature has been detected beyond the 0.95*110°C limit for the motor being monitored 温度已检测到超过 0.95 * 110°C 限制被监测电机	See error number 9010 参考错误编号 9010
41031	A	<i>Junction temperature model: Overtemperature – Movement stopped 结温模式: 过热 - 运动停止</i>	The mathematical model that calculates the theoretical temperature reached by the motor has produced a value higher than 95% of the maximum limit 由数学模型计算的电机所能达到的理论温度值超出最大极限值的 95%	See error number 9030 参考错误编号 9030

41041	A	<p><i>Bleeder temperature model: Overtemperature – Movement stopped</i> 降温模型：过热 - 运动停止</p>	<p>The mathematical model that calculates the theoretical temperature reached by the braking resistor has produced a value higher than 95% of the maximum limit 由数学模型计算的制动电阻所能达到的理论温度值超出最大极限值</p>	<p>See error number 9040 参考错误编号 9040</p>
<p>Table34: Axis errors (code 01) 2/2 表 38: 轴的错误（代码 01）2/2</p>				

2 第二章 MAINTENANCE AND ELECTRICAL REPAIRS 维修和 电器维修

2.1 Specific safety rules 具体的安全规则



WARNING 警告

Risks of various kinds, possibly of a serious nature. 各种风险以及严重的可能性



MANDATORY ACTION 强制性措施

Before performing any maintenance, make the safe.

All maintenance, repair, adjustment, cleaning work, etc. must be carried out only by suitably trained and skilled specialist personnel who have read through this instruction manual.

只有通过适当的培训和熟练的专业人员且仔细阅读使用说明书，才能进行所有的维护、修理、调整、清扫工作等必须进行。

Only use tools that are suitable for the maintenance and repair work. When working on electrical parts, only use tools insulated against electricity.

只有使用合适的工具进行维护和修理工作。对电气部件作业时，只能使用绝缘电抗工具。

Only specialist personnel are allowed to perform maintenance on electrical equipment.

只有专业的人员才允许对电气设备进行维护。

When performing maintenance, you must wear personal protective equipment and use suitable tools in a good state of repair.

进行维护时，必须佩戴个人防护设备和使用处于良好状态的维修工具。

If environmental lighting is insufficient, install a local light for maintenance work or use suitable portable devices.

如果环境照明不足，安装一个本地光源进行维护工作或使用合适的便携式设备。

Also unplug the unit from the power supply before performing any work on the ON/OFF switch.

同样在 ON / OFF 开关进行任何工作之前，从电源上拔下插头。

If the 's power cord is damaged, it is potentially hazardous and must be replaced straight away.

如果工业机器人的电源线损坏，这是潜在的危險，必须马上更换。

In the event of replacement (due to cuts, tears, etc.), the electric cable connecting the electrical cabinet to the facility's power outlet must have a suitable cross-sectional area for the length of the cable in question and the installed power. 在更换的情况下（由于切割，撕裂等等），该电气柜连接到设施电源插座的电缆必须具有合适的横截面面积以符合电缆的长度和安装功率。

Only use spare parts that are identical to the ones being replaced or that have been

authorized by the manufacturer beforehand.

只有使用相同备件才能替换原备件,或由制造商事先授权的备件。

Observe work hygiene rules while cleaning the.

清洁工业机器人时必须遵守工作卫生规则。

Refer to the instructions provided for third-party components, attached hereto.

请参阅所附提供第三方组件的说明。

Keep the work area spotlessly clean while performing maintenance and repair work.

在进行维护和维修工作时,保持工作区域的干净整洁。

Before restarting the after maintenance or an overhaul, make sure all guards and safety devices are put back in their proper place and remove any tools that have been used for the job.

在维修或大修后重新启动工业机器人,确保所有防护装置和安全装置放置于适当的位置,并移走任何作业工具。

When disposing of manufacturing waste and spare parts do so responsibly to protect the environment: do not litter!

处置废弃物制造和零部件时,要对环境保护负责:不乱扔垃圾!

Replace worn or obsolete components with equivalent new components.

用等效的新组件更换磨损或过时的组件。

Once you have finished maintenance work, you are advised to double check that you have refitted all components correctly.

一旦你已经完成维修工作,建议您仔细检查你改装所有组件正确性。



PROHIBITION 禁止

Do not perform any work other than that described herein. Seek the assistance of engineers when you plan to perform work and/or make changes that are not described herein

不要进行除本文所述外的其他任何工作。当你计划的作业或者改动的工作不在上述的内容范围,请寻求 CMA ROBOTICS SPA 工程师的协助

Do not perform any maintenance work while the is operating.

不执行任何维护工作在工业机器人运作时。

No unauthorized or unqualified personnel are allowed to perform maintenance.

未经授权的或不合格的人员不允许进行维护工作。

No makeshift repairs, made with the aid of joints or tape, are allowed.

借助关节或输送带的临时修理工作是不允许的。

If equipment has become stiff or seized up for some reason, do not use naked flames, hot air or other tools to heat the affected part.

如果设备出于某种原因已经变得老化或失灵,不要使用明火、热空气或其他工具加热受影响部分。

Never use flammable or toxic solvents to clean parts. Take adequate safety measures to avoid risks associated with the use of cleaning liquids.

切勿使用易燃或有毒溶剂擦拭部件。采取足够的安全措施,以避免使用清洗液所产生的相关风险。

2.2 Making the safe 确保工业机器人安全



WARNING 警告

Risks of various kinds, possibly of a serious nature 各种风险以及严重的可能性

MANDATORY ACTION 强制性措施

Before performing any kind of maintenance, repair or cleaning work, or any other task involving working on the, you must cut off its power and compressed air supplies by proceeding as follows:



Unplug the unit upstream from the ON/OFF switch before performing any work on the switch in question or on the relevant cables entering the unit.

Be aware of residual energy in the inverter: wait **15 minutes** to give the inverter's capacitors time to discharge.

在执行维护、修理任何一种或清洁工作，或涉及作业的机器人，你必须切断其电源，断开压缩空气供应，操作如下：

在操作电源开关或单元电缆接入工作之前，拔下 ON/OFF 开关的进线。注意残余能量的逆变器：等待 15 分钟给逆变器的电容器的时间来放电。



Figure252: Control panel on electrical cabinet
电柜上的控制面板

- Press the **STOP** button to stop the machine immediately.
- Press the **POWER ON** button to switch off the Robot's motors.
- 按 **STOP** 按钮立即停止机器。
- 按 **POWER ON** 按钮关闭机器人的电机。



Figure63:Electrical Cabinet ON/OFF switch
电柜 ON/OFF 开关



Figure64:Do Not Switch On sign
禁止打开标识

- Open the main ON/OFF switch by turning it to "0" and unplug the unit when performing maintenance work on the actual switch or on the power cord running from the outlet to the cabinet
- Attach the safety padlock and lock it. The person tasked with performing the work must keep the padlock's keys on their person while work is in progress.

- 打开主电开关将其设置为 0,在执行维修工作时,拔掉当前开关或电柜的外接电源线的进线端。
- 附加安全挂锁并将其锁住。正在作业操作的人员,要确保的挂锁的钥匙放在自己处保管。

- If the operator does not have a direct view or control of the ON/OFF switch, a 'do not switch on' sign must be placed on the switch in question reading "ROBOT UNDERGOING MAINTENANCE" in a clearly visible position.
- Before resuming the work cycle, make sure all guards and safety devices that have been removed are enabled and working correctly.

- 如果操作员不能直接观察到或控制 ON / OFF 开关的,“机器人正在进行维护”的标识符号必须放在一个清晰可见的位置。
- 恢复之前的工作周期前,确保所有防护装置和安全装置移除,才能打开时能,正常工作。

2.3Scheduled maintenance 日常维护



MANDATORY ACTION 强制性措施

To avoid breakdowns due to components deteriorating, a table of periodic scheduled maintenance must be compiled with a view to keeping the 's electrical cabinet in proper working order.

为了避免因部件故障恶化，定期维护表必须以保持对工业机器人的电柜在正常工作状态进行记录整理。

2.4 Summary of work 工作摘要

Once a month 每月 1 次	Checking and replacing the dust filter (version with forced ventilation only) 检查和更换灰尘滤尘器（强制通风版本）	2.5.1
Once a month 每月 1 次	Cleaning inside the cabinet (version with forced ventilation only) 清洗机柜内部（强制通风版本）	2.5.2
Once a month 每月 1 次	Checking operation of cabinet ventilation (version with forced ventilation only)检查机柜通风的操作（强制通风版本）	2.5.3
Every 6 months 6 个月 1 次	Checking operation of the drive and heat sink fans 检查驱动器和散热器风扇的运行	2.5.4
Once a week 每周 1 次	Checking indicators and alarm warning devices are in proper working order 检查指示灯和报警装置处于正常工作状态	2.5.5
Once a week 每周 1 次	Checking safety devices are in proper working order 检查安全装置是否处于正常工作状态	2.5.6
Once a month 每月 1 次	Checking the cabinet-robot connecting cable for damage 检查柜机器人连接电缆是否损坏	2.5.7

Tabella 35: Maintenance work 表 39: 维护工作

2.5 Description of routine maintenance work 日常维护工作说明

2.5.1 Checking and replacing the dust filter (version with forced ventilation only)检查和更换滤尘器(强制通风版本)



- Remove the protective grille by simply pulling it off with your hand
- 只需用手拉开取下保护隔栅

Figure 65:Checking and replacing the dust filter
检查和更换滤尘器



- Check the state of the filter
- 检查滤尘器的状态

Figure 66:Checking and replacing the dust filter
检查和更换滤尘器



Figure 67:Checking and replacing the dust filter
检查和更换滤尘器

- If too much dust has built up in the filter, replace it
- Refit the protective grille
- 如果过滤器累积过多灰尘，及时更换它。
- 装好防保护格栅

2.5.2 Cleaning inside the cabinet (version with forced ventilation only) 清洁 电柜内部（强制通风版本）



Figure 68:Cabinet interior
电柜内部

- Switch off the electrical cabinet
- Open the door
- Vacuum up the dust that has built up on electronic equipment
- 关闭电柜电源
- 打开柜门
- 吸出堆积在电子设备的灰尘

2.5.3 Checking operation of cabinet ventilation (version with forced ventilation only) 检查操作柜通风（强制通风版本）



Figure69: Checking operation of ventilation
检查通风操作

- Switch off the electrical cabinet
- Open the door
- With help of a clamp switch the electrical cabinet back on by operating the QS100 switch's control lever directly
- 关闭电柜电源
- 打开柜门
- 利用钳子直接操作 QS100 开关的控制杆重新打开电柜



Figure 26: Checking operation of ventilation
检查通风操作

- Locate thermostat ST21, (the one with the blue setting dial)
- Using a screwdriver, turn the setting dial anticlockwise until the fan on the cabinet's left side starts working
- Turn the setting dial back to 25°C □
- If the fan fails to start, follow the instructions given in section 012.7.8. Replacing the cooling fan (version with forced ventilation only)
- 定位温控器 ST21(蓝色的设置拨号)
- 用螺丝刀逆按顺时针方向转动拨盘，直到在箱体的左侧风扇开始工作
- 将拨盘回拨至 25°C
- 如果风扇无法启动，请按照 2.7.12 节给出的说明（强制通风版本）更换冷却风扇

2.5.4 Checking operation of the drive and heat sink fans 检查驱动器和散热器风扇的运行



Figure 71: Checking heat sink ventilation
检查散热器通风状况

- Switch off the electrical cabinet
- Open the door
- Switch the electrical cabinet back on by operating the QS100 switch's control lever directly
- 关闭电柜电源
- 打开柜门
- 通过直接操作 QS100 的控制杆开关的电气柜

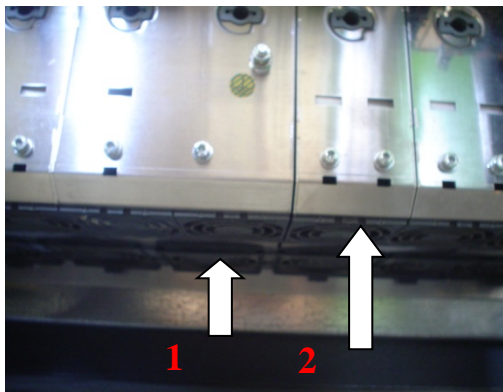

Figure 72: Checking heat sink ventilation
检查散热器通风状况

- There are two rows of fans under the drives. The first row of fans, the ones with the green LEDs, are the ones that cool the drives' heat sinks. The second row cools the drives' electronics.
- Make sure all fans are rotating correctly and that all the green LEDs are on
 - If the even one or more fans are not working, follow the instructions given in sections 012.7.4.Replacing the heat sink cooling fans 012.7.5.Replacing the drives' cooling fans.

- 驱动器下有两个风扇
风扇的第一排有绿色发光二极管，是冷却驱动器的散热片。
第二排冷却驱动器的电子设备。
- 确保所有的风扇都在正确的旋转，并且所有的绿色 LED 灯亮
 - 如果连一个或多个风扇不工作，按照 12.7.7 节更换散热器冷却风扇以及 12.7.8 节更换驱动器的冷却风扇

2.5.5 Checking indicators and alarm warning devices are in proper working order 检查指示灯和报警报警装置处于正常工作状态



Figure 73:Control Panel
控制面板

The indicators and alarm warning devices are located on the control panel on the electrical cabinet.

- Set the **AUTO – TEACH** selector to **AUTO**; the selector should light up.
- Press the **POWER ON** button; the button should light up.
- Select a program and press the **START** key; the button should light up (for information on selecting the program, see Section 4 point 5.1 Automatic cycle starting procedure).
- Press the mushroom-head **EMERGENCY** stop button; the **ALARMS** button should light up.

指标和报警预警设备位于电柜的控制面板上。

Perform the following checks:进行以下检查：

- 将选择器拨至 **AUTO – TEACH** 到自动模式；选择器的灯会亮起。
- 按下 **POWER ON** 按钮,按钮应该亮起。
- 选择程序，按 **START** 键;按钮应该亮起（有关选择程序，请参见第 4 章 5.1 节自动循环启动程序）。
- 按下蘑菇头 **MERGENCY** 急停键；**ALARMS** 按钮会亮起。

If even one of the above-described conditions fails to occur, follow the instructions given in section 2.7.11 如果上述检查出现失败的情况，请按照第 2.7.11 更换控制面板 LED 的指示

2.5.6 Checking safety devices are in proper working order 检查安全装置是否处于正常工作状态



Figure 74:Control Panel
控制面板

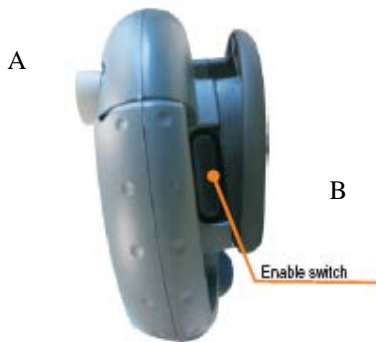

Figure 75:Pendant
示教器

- Press the mushroom-head emergency stop button on the control panel and make sure the Robot stops and that the emergency status is reported on the display
- 按下控制面板上的蘑菇头急停按钮，并确保在机器人屏幕上显示停止和急停状态报告。

- Press the mushroom-head emergency stop button on the pendant (A) and make sure the Robot stops and that the emergency status is reported on the display
- Set the Robot to teach mode, move an axis as described in section 4 under point 4.2.1 and make sure that the Robot stops when the enable switch (B) is released

- 按下示教盒上蘑菇头急停按钮（A），并确保在屏幕上显示机器人停止和紧急状态
- 设置机器为人示教模式，按第四节所述点4.2.1,移动一个轴并确保机器人停止时手压开关(B)松开



Figure 76:Perimeter fence
防护围栏

Set the Robot to automatic mode, switch on the motors, trip the safety device mounted on the perimeter fence. The motors should switch off and the display should show the Emergency condition. 将机器人调至自动模式，开启伺服，跳闸安全装置安装在防护网上。伺服关闭时，在屏幕上显示急停状态。

2.5.7 Checking the cabinet-robot connecting cable for damage 检查机器人电柜连接电缆是否损坏

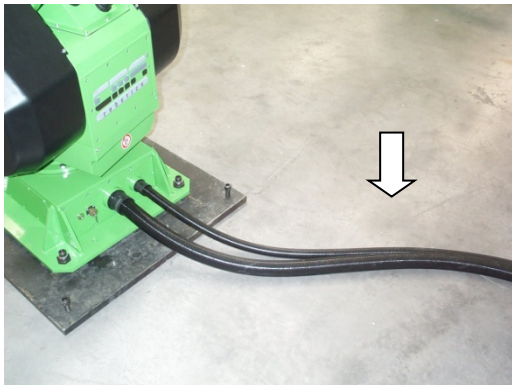

Figure 77:Checking the cabinet-robot cable for damage
机器人电柜线缆是否损坏

- Visually inspect the cable for damage, making sure the sheath has not been crushed or cut
- 目视检查是否有损坏的电缆，确保电缆外皮没有被压破或切断
- If you encounter any problem, call the CMAROBOTICS customer support department
- 如果您遇到任何问题，请致电 CMAROBOTICS 客户支持部门。

2.6 Occasional work 临时性工作

MANDATORY ACTION 强制性措施

All repair work must only be performed with the stopped and the power supply disconnected.

所有维修工作必须在工业机器人停止和电源断开时才能进行。

Work must always be performed by suitably trained personnel and every precaution must be taken to avoid accidental restarting and electrocution.

工作必须由经过适当培训的人员进行，必须采取预防措施，以避免意外重启和触电。



In the event of faults or trouble, always contact, who will be able to provide advice on how to remedy the problem, or call in your own engineer to perform repairs.

在发生故障或故障的情况下，随时联系芜湖希美埃机器人技术有限公司，就如何解决这个问题我们能提供相关建议，或者联系你的工程师进行维修。

DISCLAIM ALL LIABILITY FOR DAMAGE TO PROPERTY OR INJURY TO PERSONS AS A RESULT OF MAINTENANCE, REPAIRS OR OTHER WORK BEING CARRIED OUT ON THE WITHOUT PRIOR WRITTEN PERMISSION.

未经事先书面许可，且由于修理或其他工作所造成的财产损失或人身伤害，希美埃芜湖机器人技术有限公司否认所有与之相关的赔偿。

There is no occasional work that can be carried out by the operator without professional help
没有任何临时性工作可以由未经过专业帮助的机器人操作员来实施的。

2.7 Non-Routine Maintenance 非日常维护

The work described concerns replacing parts that are easy to replace by following the customer support department instructions and can be carried out by qualified personnel who do not necessarily belong to CMA(Wuhu) Robotics Co.,Ltd. .

所描述的涉及到更换零件的工作可以按照售后服务部的指令进行更换，且一般符合资格的人员就可以进行该工作，不一定需要希美埃(芜湖)机器人技术有限公司的人员。



MANDATORY ACTION 强制性措施

All repair work must only be performed with the stopped and the power supply disconnected.

所有的维修工作必须在机器人停止断电后进行。

Work must always be performed by suitably trained personnel and every precaution must be taken to avoid accidental restarting and electrocution.

该项工作必须由接受过适当培训的人员进行，且必须采取预防措施，以避免意外重启和触电。

In the event of faults or trouble, always contact, who will be able to provide advice on how to remedy the problem, or call in your own engineer to perform repairs.

在发生故障的情况下，随时联系希美埃芜湖机器人技术有限公司，就如何解决这个问题我们能提供相关建议，或者联系你的工程师进行维修。

When part of the and its associated electrical equipment are replaced or changed, the tests prescribed by the relevant standard (IEC EN 60204-1) must be repeated. 根据相关标准规定(IEC EN 60204-1)，机器人部件以及相关电气设备更换或改变时，相关测试工作必须重新进行。

DISCLAIM ALL LIABILITY FOR DAMAGE TO PROPERTY OR INJURY TO PERSONS AS A RESULT OF MAINTENANCE, REPAIRS OR OTHER WORK BEING CARRIED OUT ON THE WITHOUT PRIOR WRITTEN PERMISSION.

未经事先书面许可，且由于修理或其他工作所造成的财产损失或人身伤害，希美埃芜湖机器人技术有限公司否认所有与之相关的赔偿。

The following operations:操作内容如下：

- replacing the equipment' structural parts; 替换设备的结构部件
- adjustments, repairs or replacement of electrical system parts; 电气系统部件的调节、修理或替换
- maintenance work on safety and warning devices; 安全设备和警告设备的维护工作
- adjustments, repairs or replacement of control system parts; 控制系统部件的调节、修理或替换
- any other work not contemplated herein 不考虑上述内容的任何其他工作

do not qualify as regular routine maintenance work, and hence require the services of authorized specialist personnel, who can be called in by contacting the manufacturer.

不符合常规的日常工作需要拥有授权的专业服务人员进行，可以通过制造商联系他们。

In addition, other non-routine maintenance includes work performed in response to exceptional events, such as:

此外，其他非日常的维护工作包括应对突发事件，如：

- Sudden breakages 突然破损
- Periodic overhauls 定期检修

2.7.1 List of spare parts for cabinet with wiring diagram 0330 电柜备件接线

图 0330 清单

CODE 代码	DESCRIPTION 描述	Quantity 数量	ITEM CODE 事项代码	BRAND 品牌
FU11	Fuses 10x38 32A	3	RT18-32A	Tingxiang
FU12	Fuses 10x38 2A	2	RT18-2A	Tingxiang
FU13	Fuses 10x38 2A	2	RT18-2A	Tingxiang
FU23 *	Fuses 10x38 6A gG	2	RT18-6A	Tingxiang
FU31	Fuse 2A 32V	1	0913689	Phoenix Contact
FU32	Fuse 7.5A 32V	1	0913702	Phoenix Contact
FU33	Fuse 2A 32V	1	0913689	Phoenix Contact
FU34	Fuse 2A 32V	1	0913689	Phoenix Contact
FU35	Fuse 2A 32V	1	0913689	Phoenix Contact
G21	22A power supply	1	B0P0220HW00.000	B&R
G31	16A power supply	1	8B0C0160HW00.001	B&R
M21	Heat sink cooling fans	6	8BXF002.000-00	B&R
GF41	2x11.0 Kw drives	1	8BVI0220HWD0.000-1	B&R
	Scheda slot 1	1	8BAC0120.000-1	B&R
	Scheda slot 2	1	8BAC0120.000-1	B&R
	Ventola raffred damento	2	8BXF001.0000-00	B&R
GF81	1x16.0 Kw drive	1	8BVI0110HWS0.000-1	B&R
	Slot 1 board	1	8BAC0120.000-1	B&R
	Slot 2 board			
	Cooling fan	1	8BXF001.0000-00	B&R
GF101	2x5.5 Kw drives	1	8BVI0055HWS0.000-1	B&R
	Slot 1 board	1	8BAC0120.000-1	B&R
	Slot 2 board			
	Cooling fan	1	8BXF001.0000-00	B&R
GF121	1x5.5 Kw drive	1	8BVI0028HWD0.000-1	B&R
	Slot 1 board	1	8BAC120.000-2	B&R
	Slot 2 board	1	8BAC0120.000-1	B&R
	Cooling fan	2	8BXF001.0000-00	B&R
A281	Safety PLC	1	986232	Phoenix Contact
	Pendant	1	Ke Top T55-raw-AU0-CE6	KEBA

Table 36: List of spare parts for cabinet with wiring diagram 01-QE-0330/xx 表 40:电柜备件接线图清单 01-QE-0330/xx				

NOTA *: With Air-Condition use 6A Fuses 注*: 空调使用 6A 保险丝

2.7.2 Replacing fuses 更换保险丝

The following table features the code of the fuses and possible alarms shown on the pendant display owing to the fuse in question blowing.

下表提供了由于保险丝的烧断而在示教盒上显示的保险丝代号和可能的报警。

ODE	Type	N°	Message
FU31	33	1	Robot in Emergency mode 机器人紧急模式
	11	1	Robot not getting air 机器人没有空气
	11	3	Thermal Cutouts tripped 热熔断器跳闸
	11	9	Cabinet temperature over limit 柜内温度超过极限

Table37:Cross-reference between fuse code and alarm displayed on pendant 表 41:保险丝代码和示教器上的报警之间的参考列表

The following table gives the code of the fuses and what trouble can be encountered.

下表给出了保险丝的代号以及可能遇到的麻烦。

ODE	Malfunction
FU11	Cabinet fails to switch on 电柜未能接通
FU12	Cabinet fails to switch on 电柜未能接通
FU32	Either the Mobile Panel or the Display fails to switch on no 移动面板或显示器无法打开
FU33	Conveyor synchronization encoder failing to count 输送机同步编码器无法计数
FU33	System management encoder failing to count 系统管理编码器无法计数
FU33	No voltage on X3 terminal block output signalX3 接线盒上没有电压输出信号
FU34	No power to robot I/O modules 机器人 I/O 模块未通电
FU35	Inputs from external equipment malfunctioning 外部设备输入发生故障

Table38:Cross-reference between fuse code and malfunction encountered 表 42:保险丝代号和故障之间的参考列表



Switch off the cabinet and open the door
Locate the fuse to be replaced
Fuses FU11,FU12 e FU13 are to be found next to the transformer

关闭电柜电源，打开柜门。
确定保险丝的位置并更换。
保险丝 FU11、 FU12、FU13 在变压器旁边。

Figure78:Replacing fuses
更换熔断器



Lamellar fuses FU31,FU32,FU33,FU34,FU35 are located next to the general isolator and are fitted with a red LED.

The LED is on when the fuse is blown.

片状熔断器 FU31、 FU32、 FU33、 FU34、FU35 位于一般隔离器旁，且配备有一个红色的 LED 灯。

LED 在保险丝熔断时亮起。

Figure79:Replacing fuses
更换熔断器



Replacing the 10x38 fuse: 替换 10x38 的熔断器

- Pull the fuse carrier cover down
- Hold the 10x38 fuse and pull it out.
- Insert the new fuse and close the cover.

- 把保险丝保护盖打开
- 拿住 10x38 保险丝并拔出来
- 插入新的保险丝，盖上保护盖。

Figure80:Replacing fuses
更换熔断器



Figure81:Replacing fuses
更换熔断器

Replacing lamellar fuses:更换片状熔断器:

- Take out the blown fuse, using the extractor shown in the figure below
- Insert the new fuse
- 取出熔断的保险丝，使用如图中所示的分离器
- 插入新的熔断器



Lamellar fuse extractor 片状熔断器的分离器

Figure82:Replacing fuses
更换熔断器



MANDATORY ACTION 强制性措施

Refer to the amp rating given on the actual fuse and on the wiring diagram and only replace a fuse with another one of the same size.

参阅实际熔断器定的额定电流和布线图上和只更换保险丝用另一个相同大小的。

The size of fuses FU22 is 380V / 400V, if power is 220V double the size
如果电源是 220 v 的两倍大小，保险丝 FU22 的大小是 380 v / 400 v

2.7.3 Replacing a drive 更换驱动器

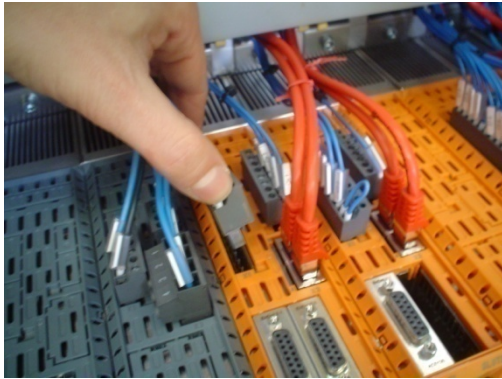

Figure 83: Replacing a drive
更换驱动器

Disconnect all the connectors on the top
断开顶部所有连接端子

- Enable connectors (coloured blue)
- Ethernet connectors (coloured red)
- Feedback connectors (coloured green)

- 使能连接端（蓝色）
- 以太网连接端（红色）
- 反馈连接端（绿色线）



Figure 84: Replacing a drive
更换驱动器

Disconnect all the connectors underneath
Motor cable connectors (coloured orange)
Brake cable connectors (coloured grey)

断开所有驱动器底部的连接端子
电机线缆连接端子（橙色）
抱闸线缆连接端子（灰色）

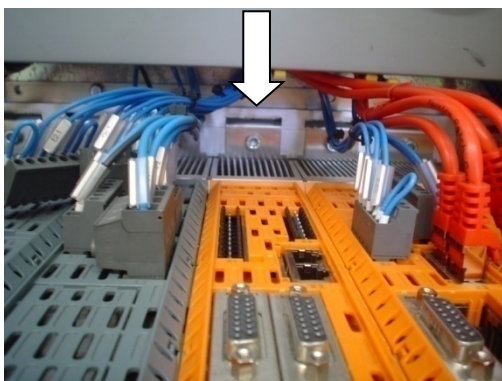
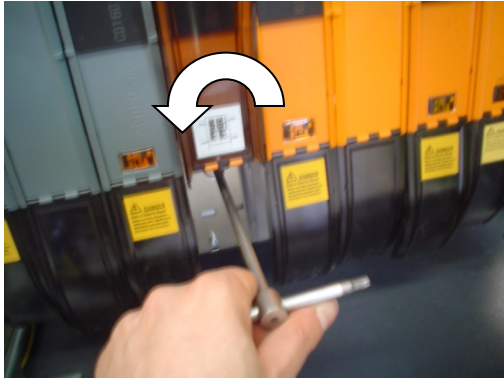

Figure 85: Replacing a drive
更换驱动器

Unscrew the fastening bolt indicated in the
photograph using a size 5 Allen key

使用 5 号内六角扳手拧开在图中所示的紧固螺栓



Unscrew the bolt indicated in the photograph using a size 5 T-handle Allen key
拧使用 5 号 T 型手柄内六角扳手拧开图中所示的螺栓

Figure86:Replacing a drive
更换驱动器



Lift the drive, pushing it up from underneath and remove it completely.
提起驱动器，从下部拉出，并彻底将它取出。

Figure 87:Replacing a drive
更换驱动器

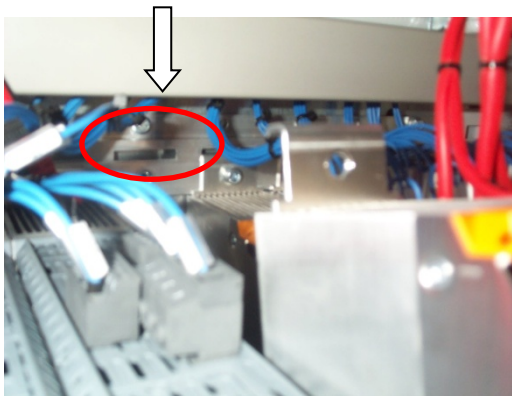

- Insert the new drive in the old drive's slot, hooking it in at the top. The arrow in the photograph indicates the slot you need to hook the drive into.
- 在旧的驱动器插槽中插入新的驱动器，钩挂在背板顶部。图片中的箭头指示了需要钩挂的驱动器的插槽。

Figure 88:Replacing a drive
更换驱动器

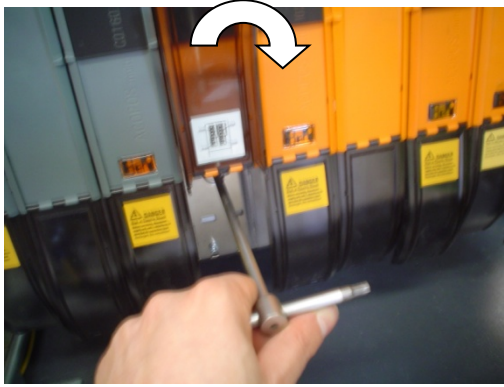

Figure 89: Replacing a drive
更换驱动器

- Tighten both M6 bolts with the size 5 Allen key. Do not apply more than 5Nm force.
- Reconnect all cables disconnected earlier
- 用 5 号内六角扳手拧紧这两个 M6 螺栓。不要使用超过 5Nm 的力矩。
- 尽快将所有断开线缆重新连接



Figure 90: Replacing a drive
更换驱动器

- Open the hinged cover and set the drive's address, as indicated in the tables below.
- 打开铰链盖，并设置驱动器的地址，如下表所示。

	GF41	GF81	GF101	GF121
High	0	0	0	0
Low	2	3	4	5

Table 39: Addresses
表 43: 地址

2.7.4 Replacing the heat sink cooling fans 更换散热器散热风扇

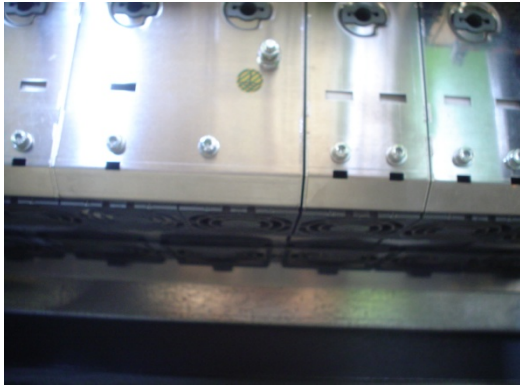

Figure91:Replacing heat sink cooling fans 更换散热器风扇

- Switch off the electrical cabinet and open the door
- The heat sink cooling fans are the ones furthest in (on the first row)
- Push in the two tabs indicated by the arrows
- 关闭电柜电源，打开柜门
- 散热器冷却风扇都在最里面（在第一行上）
- 压进由箭头指示的两个卡扣

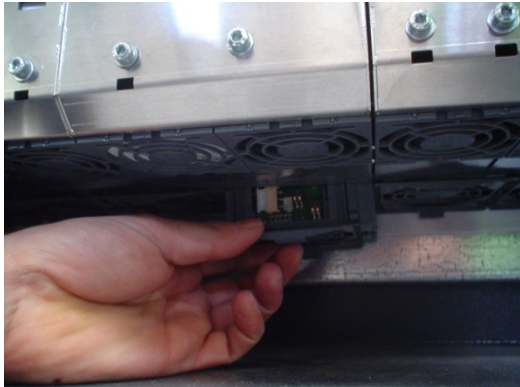

Figure92:Replacing heat sink cooling fans 更换散热器风扇

- The cooling fan will want to come out of its housing
- Support it as you allow it to drop, removing it gently
- Insert the new cooling fan in the old one's place
- 冷却风扇会自然从安装位置弹出。
- 当风扇掉落时需要用手托住,并轻轻地取下它
- 将新的冷却风扇插入原先的安装位置

2.7.5 Replacing the drives' cooling fans 更换驱动器的散热风扇

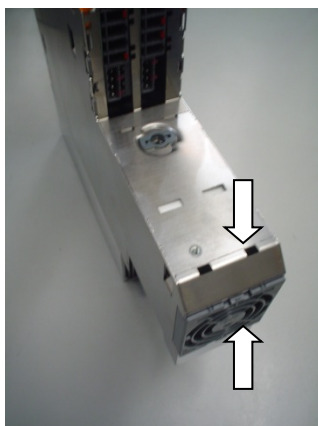

Figure 93:Replacing the drives' cooling fans 更换驱动器的散热风扇

- Switch off the electrical cabinet and open the door
- Disassemble the drive whose fan you wish to replace following the instructions in paragraph 12.7.4 Replacing a drive
- Push out the two retainers as illustrated
- Pull out the fan
- 关闭电柜电源，打开柜门
- 按照 2.7.4 节更换驱动器的说明拆开需要更换的驱动的风扇。
- 推出两个保护罩，如图所示
- 拿出风扇



Figure94 Replacing the drives' cooling fans

更换驱动器的散热风扇

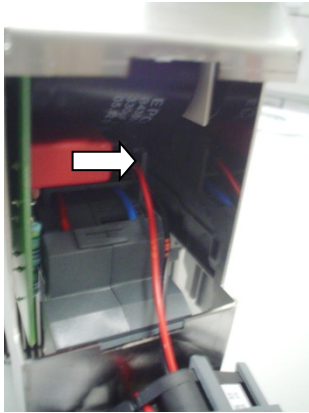

Figure95 Replacing the drives' cooling fans

更换驱动器的散热风扇

- Press the fastener at the end of the fan's cable
- Once you have pulled the old fan all the way out, replace it with the new one, reconnecting the power supply cable inside the drive
- Reposition the fan
- Rethrive drive

- 按下风扇线缆底部的紧固扣件。
- 一旦你将旧风扇取出来，用新的替换它，重新连接驱动器内的电源线
- 重新放置风扇
- 复查驱动器

2.7.6 Replacing the safety PLC 更换安全 PLC

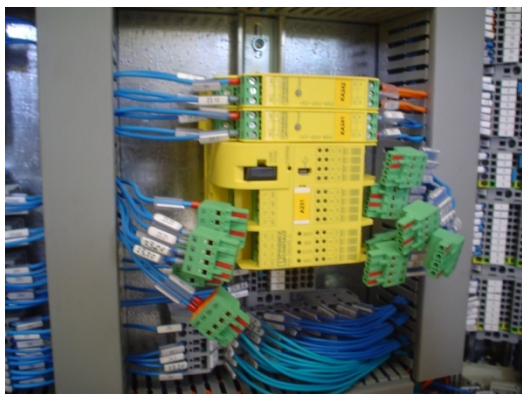

Figure27: Replacing the safety PLC
更换安全 PLC

- Switch off the electrical cabinet.
- Disconnect the connectors on the top and underneath the PLC. The connectors are marked with a reference number, making it impossible to get them the wrong way round if they are reconnected.
- 断开电柜电源
- 断开 PLC 顶部和底部的接线端子。这些端子需要相关的号码做标记，以确保重新连接时不会接错。

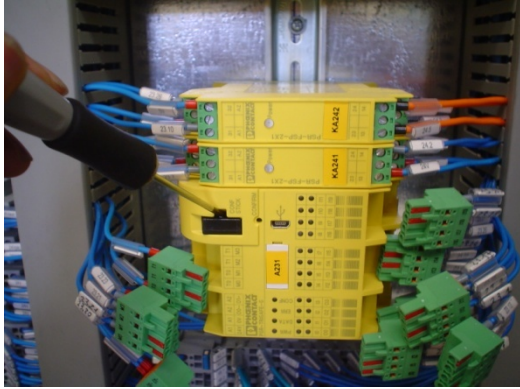

Figure28:Replacing the safety PLC
更换安全 PLC

- Remove the black Memory Stick, levering it out gently with a screwdriver.
- 取下黑色的记忆棒时，用螺丝起轻轻地将其撬起。

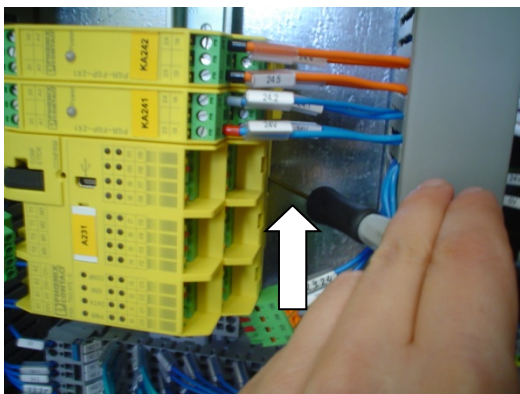

Figure 98:Replacing the safety PLC
更换安全 PLC

- Use a screwdriver pressed down on the retaining tab to lever the PLC out from its supporting rail.
- 使用螺丝刀下压止动垫片，将从 PLC 从安装导轨上撬出来。

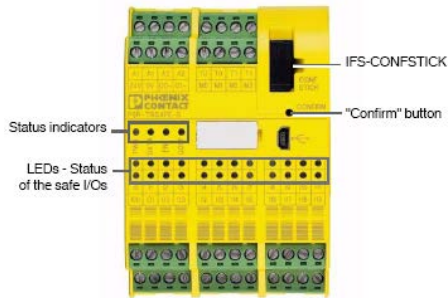

Figure29:Replacing the safety PLC
更换安全 PLC

Fit the new PLC and reconnect the connectors
安装新的 PLC 并重新连接到端子排上。

Insert the old PLC's Memory Stick (IFS-CONFSTICK) in the new PLC while it is switched off, then switch the electrical cabinet back on and wait until the PLC booting up procedure is done; the CONF LED will flash once it has finished.

将旧 PLC 的记忆棒（IFS-CONFSTICK）插入到新的 PLC 时将 PLC 关闭，然后打开电气柜重新开启，等到 PLC 开机程序完成的;一旦完成，CONF 会闪烁。

Remove the Memory Stick while the PLC is

switched on

PLC 接通时取出记忆棒

Hold down the Confirm key

按住确认键

Refit the Memory Stick while still holding down the Confirm key

同时仍按住确认键，重新装上记忆棒

Once the Memory Stick has been inserted, release the Confirm key and wait for the PLC to initialize

一旦已插入记忆棒，松开确认键，并等待 PLC 初始化

2.7.7 Replacing the Display (only APS version) 更换显示器(只有 APS 版本)



Figure30: Replacing the *Display*
更换显示器

- Switch off the cabinet, open the door and lift the control panel
- Disconnect the DVI-USB power and ground cables.
- 关闭电柜电源，打开柜门，抬起控制面板。
- 断开 DVI-USB 接口，以及电源线和地线。



Figure3101: Replacing the *Display*
更换显示器

- Remove all the display clasps
- 移除所有显示器周边的扣环



Figure 32: Replacing the *Display*
更换显示器

Take care when removing the last clasp so that the display does not fall off the control panel.
去掉最后的扣环时要小心，确保显示器不会从控制面板上掉落。

- Insert the new display and reconnect all cables.
- Fix the display to the control panel with its clasps.

- 插入新的显示器，并重新连接所有电缆。
- 用扣环将显示器固定到控制面板。

2.7.8 Replacing the cooling fan (version with forced ventilation only) 更换冷却风扇（强制通风版本）

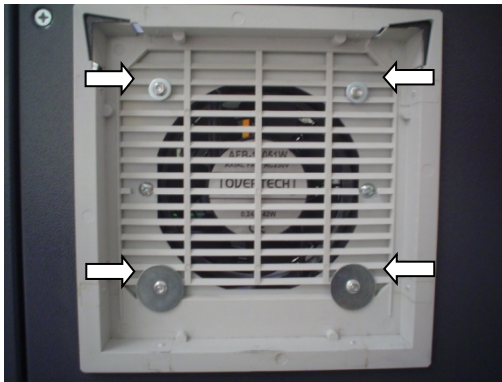

Figure 33: Replacing the cooling fan
更换冷却风扇

- Switch off the electrical cabinet and open the door
- Disconnect wires n°113 and n°106 from the terminal
- Unscrew the fan's four fastening screws and remove it
- Fit the new fan and fasten it like the old one
- Reconnect the wires to the terminal

- 关闭电柜电源，打开柜门
- 在风扇接线端子上断开电线 n°113 和 n°106
- 拧开风扇的四个固定螺丝，并取下
- 安装新的风扇，并像之前的方式拧紧它
- 重新连接线到接线端子

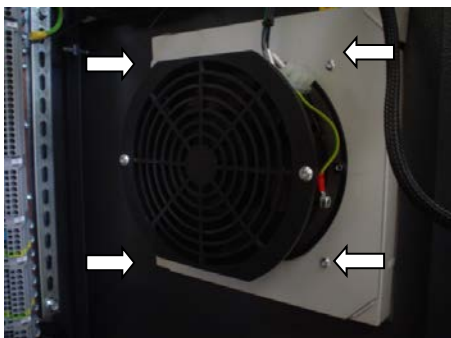

Figure 34: Replacing the cooling fan
更换冷却风扇